



# TECHNICAL NOTES on Brick Construction

1850 Centennial Park Drive, Suite 301, Reston VA 20191 | [www.gobrick.com](http://www.gobrick.com) | 703-620-0010

## Technical Notes 19B - Residential Chimneys - Design and Construction Rev [June 1980] (Reissued Apr. 1998)

**Abstract:** All residential chimneys, both for fireplaces and appliances, are designed and constructed to serve the same basic functions. They must provide fire protection and safely convey combustion by-products to the exterior of the structure at a rate that does not adversely affect the combustion process. Design, materials selection, construction, and building code requirements all have a significant impact on the chimney's potential to fulfill these functions. Chimney height and flue area are the two most critical factors in chimney design.

**Key Words:** bricks, building codes, chimneys, draft, flashing, flues, masonry, mortar.

### INTRODUCTION

This *Technical Notes* addresses the design and construction of residential chimneys. Other *Technical Notes* in this Series deal with residential fireplaces and commercial chimneys. The design of residential chimneys is empirical and based on successful prototypes. The function of residential chimneys is to allow combustion by-products to be conducted away from the structure safely.

### GENERAL

Residential chimneys generally fall into two categories: 1) chimneys serving fireplaces, and 2) chimneys serving appliances. While there are dissimilarities between the two types, they both serve the same basic functions. It is worthwhile, therefore, to consider their similarities. Both are constructed of similar materials and must meet the same building code requirements. Even though they may convey different combustion by-products at different velocities, they both must be designed and constructed to discharge these by-products at a rate that does not adversely affect the combustion process and to release the discharged material at a height and location that provides fire safety.

Flues may slope to join with other flues so as to discharge through a common flue, or to achieve the desired location of the chimney. The maximum allowable slope is 30 deg from vertical. When combining flues the main discharge flue should be sized for the maximum combined flow from the smaller flues. Combining flues of dissimilar systems or fuels, i.e., appliances and fireplaces, is not allowed by many building codes. Separate flues may be incorporated into one chimney so long as minimum wall thickness requirements are met and a full wythe of brick is laid between them and bonded to the chimney walls.

### Building Code Requirements

Building code requirements for chimneys may vary on a local basis. There are, however, several that are accepted nearly everywhere. They include:

1. Chimney wall thickness should be a nominal 4 in. (100 mm) unless no flue liner is used, in which case a nominal 8 in. (200 mm) is required.
2. Neither chimney nor flue liner may change size or shape within 6 in. (150 mm) of either floor components, ceiling components or rafters.
3. The minimum chimney height for fire safety is the greater of 3 ft (1.0 m) above the highest point where the chimney penetrates the roofline, or 2 ft (600 mm) higher than any portion of the structure or adjoining structures within 10 ft (3.0 m) of the chimney, see Fig. 1.

4. Chimney clearance from combustible material is a minimum of 2 in. (50 mm) except where the chimney is located entirely outside the structure, in which case 1 in. (25 mm) is acceptable.
5. The spaces between a chimney and combustible material should be firestopped using a minimum of 1-in. (25 mm) thick noncombustible material.
6. All exterior spaces between the chimney and adjacent components should be sealed. This is most commonly accomplished by flashing and caulking.
7. Masonry chimneys should not be corbeled more than 6 in. (150 mm) from a wall or foundation nor should a chimney be corbeled from a wall or foundation which is less than 12 in. (300 mm) in thickness unless it projects equally on each side of the wall, except that on the second story of two-story dwellings corbeling of chimneys or the exterior of the enclosing walls may equal the wall thickness. Corbeling may not exceed 1-in. (25 mm) projection for each course of brick protected.

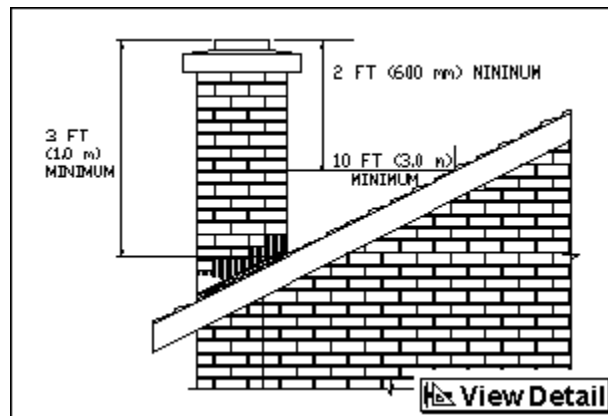

**Building Code Dimension Requirements**

**FIG. 1**

## **Recommendations**

In many situations it may be desirable to use the chimney as a structural element. This may be accomplished within most building codes by maintaining the chimney wall thickness and adding a structural wall around the chimney. This structural wall may be built integrally with the chimney wall. Most building codes require a minimum of 4 in. (100 mm) of bearing. Considering all the building code dimensional requirements, the minimum wall thickness of a lined chimney to be used as a structural component is 10 in. (250 mm) consisting of: 1) 4-in. (100 mm) chimney wall (brick), 2) 2-in. (50 mm) of noncombustible material (brick), and 3) 4-in. (100 mm) bearing length (brick). An unlined chimney's minimum wall thickness is 14-in. (350 mm) consisting of the same elements as the lined chimney except that the chimney wall must be 8-in. (200 mm), see Fig. 2.

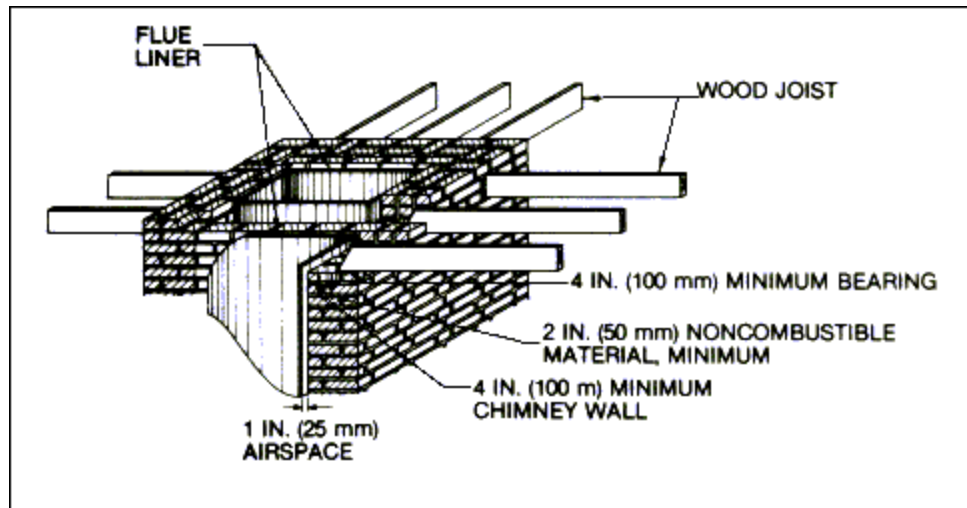

**Chimney Used as Structural Support**

**FIG. 2**

## **MATERIALS**

### **Brick**

The chimney, by the nature of its function, is at least partially exposed to weathering. The brick should conform to ASTM C 216, Grade SW, or ASTM C 62, Grade SW, to assure sufficient durability. Paving brick should conform to ASTM C 902, Class SX.

### **Mortar**

To allow for both weathering and thermal considerations, Type N portland cement-lime mortar is recommended for the chimney. Type S portland cement-lime mortar is acceptable, and may be necessary when the chimney is subjected to high lateral forces such as wind loads in excess of 25 psf (1.2 kPa) or seismic loads. Where the chimney is in contact with earth, Type M portland cement-lime mortar is recommended. The mortar used to bed the flue liners should be able to perform well under high temperatures. Therefore, fireclay mortars are highly recommended. Type N portland cement-lime mortar is an acceptable substitute. For a comprehensive discussion of portland cement-lime mortar types and uses, see *Technical Notes 8 Series*.

### **Flue Liners**

Flue liners should conform to ASTM C 315. They should be thoroughly inspected just prior to installation for cracks or other damage that might contribute to smoke and flue gas leakage.

### **Flashing**

Corrosion-resistant sheet metal flashing is required by most building codes. Quality materials should be specified since replacement may be expensive and troublesome. See *Technical Notes 7A Revised* for selection of flashing materials.

### **Chimney Caps**

A prefabricated chimney cap similar to the one shown in Fig. 3 should be used. This type cap provides better durability and is more easily made water-resistant than a cast-in-place cap. When a cast-in-place cap is used, it should incorporate the same shape as the prefabricated. The thickened sides and overhangs will reduce the potential for water penetration.

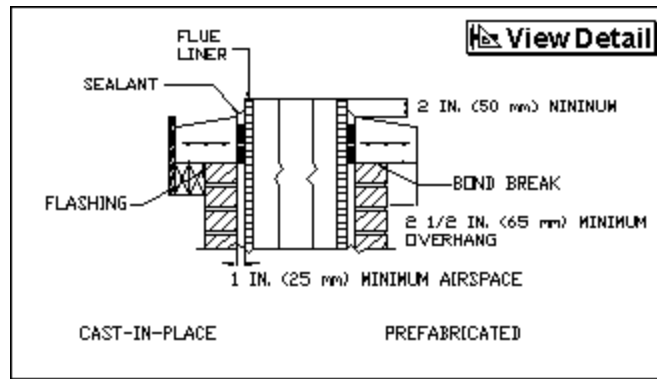

**Chimney Cap Detail**

**FIG. 3**

### Rain Caps

Rain caps vary from sophisticated turbine type metal caps to simple slabs set above the termination point of the flue liner. When specifying a manufactured rain cap, information regarding its effect on the gas flow through the chimney should be obtained from the manufacturer. If the cap is metal, it should be corrosion-resistant.

### Sealants

Caulking is frequently considered a means of correcting or hiding poor workmanship, rather than as an integral part of construction. It should be detailed and installed with the same care as the other elements of the structure. In all cases, the use of a good grade, polysulfide, butyl, or silicone rubber sealant is recommended. Oil-based sealants should not be used. Regardless of the sealant used, proper priming and backing rope, are a must.

### Ties and Reinforcement

Ties used in chimney construction should be corrosion-resistant metal ties. For a general discussion of ties and their placement, refer to *Technical Notes 28 Revised*.

Reinforcing steel should conform to one of the following ASTM Standards:

1. Welded Wire-ASTM A 185
2. Steel Bar-ASTM A 615, ASTM A 616 or ASTM A 617
3. Wire-ASTM A 82

### DESIGN

Design of fireplace and appliance chimneys is limited to the determination of height requirements that when used in conjunction with proper flue sizes, detailing and construction will provide adequate draft. Building code requirements for minimum chimney height remain in effect and must be met or exceeded.

### Fireplace Chimneys

The design of residential fireplace chimneys is directly related to: 1) the area of the fireplace opening, 2) the area of the flue liner, and 3) the height of the chimney. In most situations, the area of the fireplace opening is controlled by considerations other than the performance of the system, such as aesthetics. The other components of the system are usually designed based upon the desired fireplace opening.

A frontal face velocity of 0.80 ft per second (0.245 m/sec) at the fireplace opening has been accepted by the American Society of Heating, Refrigerating and Air-Conditioning Engineers (ASHRAE) to be sufficient to prevent smoke and gases from being discharged into habitable spaces. This is a minimum velocity and usually only

encountered while starting a fire. Flue liner size as a function of fireplace opening size may be obtained from *Technical Notes 19 Revised*, Table 1.

TABLE 1  
Typical Flue Liner Dimensions

Nominal Size in.	Inside Perimeter, P <sub>i</sub> ft	Equivalent Diameter, D in.	Minimum Area, A <sub>F</sub> sq ft
8 x 12	2.7	9	0.42
12 x 12	3.0	10	0.56
12 x 16	3.6	12	0.78
16 x 16	4.2	14	1.08
16 x 20	4.8	16	1.38
20 x 20	5.3	18	1.78
20 x 24	5.9	20	2.16
24 x 24	6.5	22	2.64

With the opening and flue sizes known, Equation 4 may be used to calculate the minimum chimney height to provide adequate draft in a properly designed, detailed and constructed assembly. The height calculated using Equation 4 is measured from the top of the fireplace opening, and is the minimum required to produce an adequate draft. Building code requirements previously discussed for minimum chimney heights are based solely on fire safety considerations and must always be met or exceeded.

### Procedure

**Step 1.** From Table 1 in *Technical Notes 19 Revised* select fireplace opening dimensions A and B and the corresponding flue liner size, L and M. Using Equation 1 calculate the Fireplace Opening Area, A<sub>o</sub>. From Table 1 determine the Minimum Flue Area, A<sub>F</sub>, using L and M.

$$A_o = \frac{A \text{ in.} \times B \text{ in.}}{144 \text{ in.}^2 / \text{ft}^2} \quad (1)$$

**Step 2.** The Flue Friction Coefficient, K<sub>T</sub> must now be determined. The friction loss due to the acceleration of ambient air to Flue Gas Velocity, K<sub>1</sub> is always equal to 1.0 in residential applications.

Based on the size of the flue selected, a preliminary damper size must be assumed. At this point in the design process, it is only necessary to decide if the damper throat area to be used will be equal to or twice the flue area. Once this decision has been made the Inlet Loss Coefficient, K<sub>2</sub>, may be determined. If the damper throat area is equal to the flue area, K<sub>2</sub> is equal to 2.5. If the damper throat is twice the flue area, K<sub>2</sub> is equal to 1.0.

At this time decisions concerning general fireplace configuration must be made. The designer must determine whether or not to use a rain cap and if so, at what distance above the chimney termination point it will be placed.

The Termination Coefficient, K<sub>3</sub>, may be selected using this information. If no rain cap is used K<sub>3</sub> equals 0.0. If a rain cap is set at a distance of D/2 (see Table 1 for equivalent diameter, D) above the termination point of the flue liner, K<sub>3</sub> may vary from 0.0 to 4.0. This information may be obtained from the manufacturer.

Having determined K<sub>1</sub>, K<sub>2</sub>, and K<sub>3</sub>, the Flue Friction Coefficient, K<sub>T</sub>, may be calculated using Equation 2.

$$K_T = K_1 + K_2 + K_3 \quad (2)$$

**Step 3.** From Table 1 determine the Minimum Flue Area, A<sub>F</sub>, using L and M.

$$A_o = \frac{A \text{ in} \times B \text{ in.}}{144 \text{ in.}^2 / \text{ft}^2} \quad (1)$$

**Step 2.** The Flue Friction Coefficient,  $K_T$  must now be determined. The friction loss due to the acceleration of ambient air to Flue Gas Velocity,  $K_1$  is always equal to 1.0 in residential applications.

Based on the size of the flue selected, a preliminary damper size must be assumed. At this point in the design process, it is only necessary to decide if the damper throat area to be used will be equal to or twice the flue area. Once this decision has been made the Inlet Loss Coefficient,  $K_2$ , may be determined. If the damper throat area is equal to the flue area,  $K_2$  is equal to 2.5. If the damper throat is twice the flue area,  $K_2$  is equal to 1.0.

At this time decisions concerning general fireplace configuration must be made. The designer must determine whether or not to use a rain cap and if so, at what distance above the chimney termination point it will be placed.

The Termination Coefficient,  $K_3$ , may be selected using this information. If no rain cap is used  $K_3$  equals 0.0. If a rain cap is set at a distance of  $D/2$  (see Table 1 for equivalent diameter,  $D$ ) above the termination point of the flue liner,  $K_3$  may vary from 0.0 to 4.0. This information may be obtained from the manufacturer.

Having determined  $K_1$ ,  $K_2$ , and  $K_3$ , the Flue Friction Coefficient,  $K_T$ , may be calculated using Equation 2.

$$K_T = K_1 + K_2 + K_3 \quad (2)$$

**Step 3.** From Table 1 determine the Inside Perimeter,  $P_I$ , of the flue liner previously selected and using Equation 3 calculate the Hydraulic Radius,  $R_H$ .

$$R_H = \frac{A_F}{P_I} \quad (3)$$

**Step 4.** The general design equation for chimneys with rectangular flues (Equation 4) may now be used to calculate the Minimum Height,  $H$ , to produce adequate draft.

This is the height of the chimney from the lintel above the fireplace opening. To obtain the height from the combustion chamber floor, add the opening height. Building code requirements for minimum chimney heights remain in effect. The greater of the values obtained from calculations and building code requirements should be used.

$$H = \frac{K_T}{\left[ \frac{5A_F}{A_o} \right]^2 - \frac{0.0083}{R_H}} \quad (4)$$

### Example

**Step 1.** From Table 1 in *Technical Notes 19 Revised* fireplace opening dimensions of 30 in. x 29 in. and a corresponding flue liner size of 12 in. x 12 in. were selected. Using Equation 1 calculate  $A_o$ .

$$A_o = \frac{30 \text{ in.} \times 29 \text{ in.}}{144 \text{ in.}^2 / \text{ft}^2} = 6.04 \text{ ft}^2 \quad (1)$$

From Table 1

$$A_F = 0.56 \text{ ft}^2$$

**Step 2.** Assuming that there is no rain cap and that the damper throat area is twice the flue area, Equation 2 may be utilized.

$$K_T = 1.0 + 1.0 + 0.0 = 2.0 \quad (2)$$

**Step 3.** From Table 1 determine  $P_i$  and solve Equation 3 for the Hydraulic Radius.

$$R_H = \frac{0.56 \text{ ft}^2}{3.0 \text{ ft}} = 0.19 \text{ ft} \quad (3)$$

**Step 4.** Substitute these values into Equation 4 and calculate the Minimum Height,  $H$ , to provide adequate draft.

$$H = \frac{2.0}{\left[ \frac{5(0.56)}{6.04} \right]^2 - \frac{0.0083}{0.19}} = 11.68 \text{ ft} \quad (4)$$

## Appliance Chimneys

Appliance chimneys are divided into two types those venting one appliance, see Fig. 4, and those venting two or more appliances, see Fig. 5. The two variables that are most commonly known to the designer are the input rating and configuration of the system. Typical design criteria are shown in Tables 2 and 3. Building code requirements for chimney heights should be considered as minimum heights for fire safety and should be strictly adhered to.

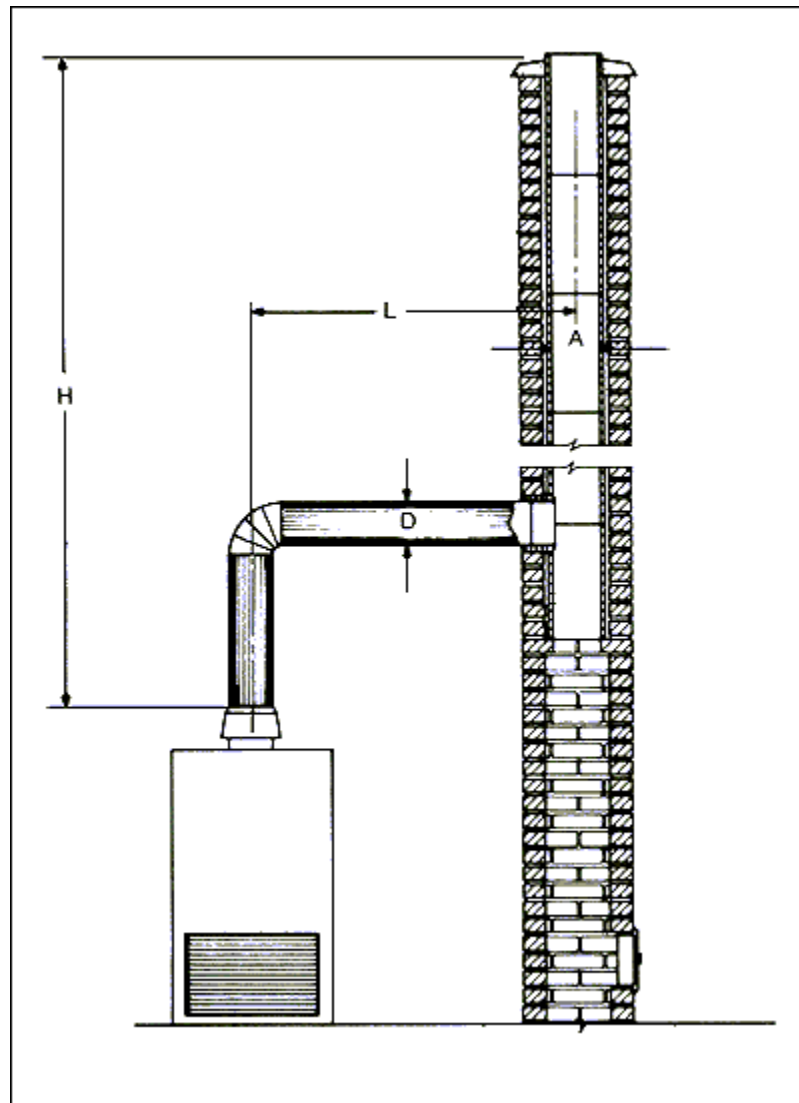

Masonry Chimney Serving a Single Appliance (See Table 2)



FIG. 4

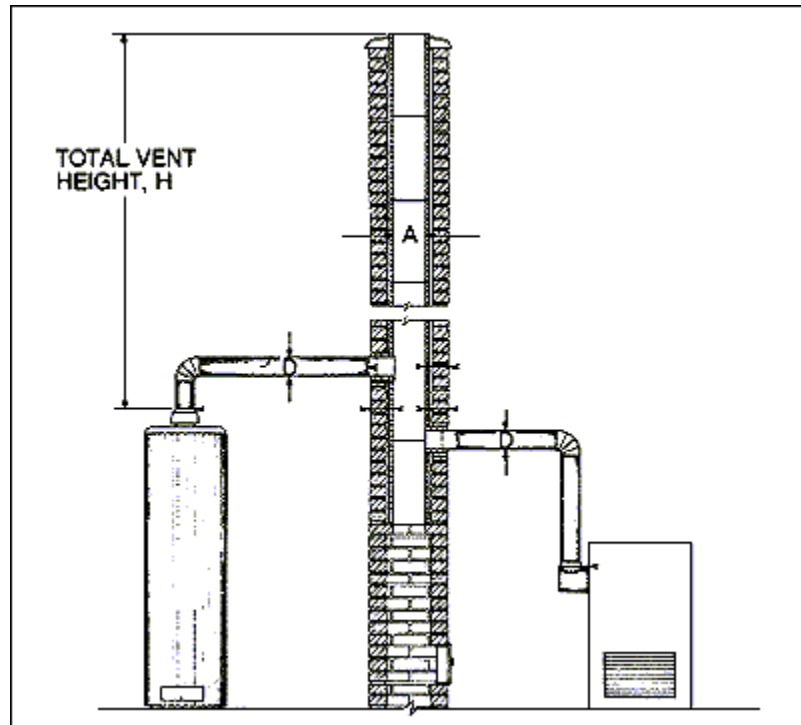

Masonry Chimney Serving Two or More Appliances (See Table 3)

FIG. 5

**TABLE 2**  
**Capacity of Masonry Chimneys**  
**Serving a Single Appliance<sup>a</sup>**  
**(Maximum Appliance Input Rating, Thousands of Btu/h)**

Height H, Feet	Lateral L, Feet	Minimum Internal Area of Chimney, A, Square Feet				
		0.26	0.35	0.47	0.66	0.92
6	2	130	180	247	400	580
	5	118	164	230	375	560
8	2	145	197	265	445	650
	5	133	182	246	422	638
	10	123	169	233	400	598
10	2	161	220	297	490	722
	5	147	203	276	465	710
	10	137	189	261	441	665
	15	125	175	246	421	634
15	2	178	249	335	560	840
	5	163	230	312	531	825
	10	151	214	294	504	774
	15	138	198	278	481	738
	20	128	184	261	459	706
20	2	200	273	374	625	950
	5	183	252	348	594	930
	10	170	235	330	562	875
	15	156	217	311	536	835
	20	144	202	292	510	800
30	2	215	302	420	715	1110
	5	196	279	391	680	1090
	10	182	260	370	644	1020
	15	168	240	349	615	975
	20	155	223	327	585	932
	30	NR <sup>b</sup>	182	281	544	865
50	2	250	350	475	810	1240
	5	228	321	442	770	1220
	10	212	301	420	728	1140
	15	195	278	395	695	1090
	20	180	258	370	660	1040
	30	NR <sup>b</sup>	NR <sup>b</sup>	318	610	970
		6	7	8	10	12
Single-Wall Vent Connector Diameter, D, Inches						

aSI conversions: W = Btu/h x 0.293; m = ft x 0.3048; mm = in. x 25.4; mm<sup>2</sup> = in.<sup>2</sup> x 645

bNot recommended.

**TABLE 3**  
**Capacity of a Masonry Chimney**  
**Serving Two or More Appliances<sup>a</sup>**  
**(Combined Appliance Input Rating, Thousands of Btu/h)**

Total Vent Height H, Feet	Minimum Internal Area of Chimney, A, Square Feet			
	0.26	0.35	0.54	0.79
6	102	142	245	NR
8	118	162	277	405
10	129	175	300	450
15	150	210	360	540
20	170	240	415	640
30	195	275	490	740
50	NR <sup>b</sup>	325	600	910

aSI conversions: W = Btu/h x 0.293; m = ft x 0.3048; mm = in. x 25.4.

bNot recommended.

## CONSTRUCTION AND DETAILS

### General

Since both fireplace and appliance chimneys have an identical function, their construction methods and materials are similar. Building code requirements insofar as construction is concerned are identical.

### Fireplace Chimneys

**General.** The chimney of a fireplace is considered to be that portion of the fireplace from the base of the first flue liner to the top of the last flue liner, or any rain cap above it.

Single-wythe chimneys should be attached to the structure. This is generally accomplished by using corrosion-resistant metal ties spaced at a maximum of 24 in. (600 mm) on center. Multi-wythe chimneys that are not masonry bonded should be bonded together using metal wire ties.

**Racking.** Chimneys are generally not as wide as the body of the fireplace below. When racking back to achieve the desired dimensions or location of the chimney care must be exercised to insure that, since there is no limitation on the distance each unit may be racked, cores of the units are not exposed. Preferred construction consists of a setting bed over the racked face with uncured or paving brick set to provide a weather resistant surface. Mortar washes may also be used. They may not, however, be as durable. When using a mortar wash it should not bridge over the rack, but should fill each step individually. Both methods of racking are shown in Fig. 6.

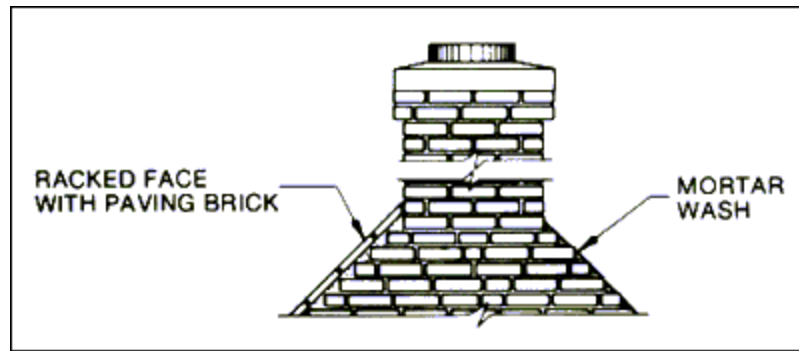

Racking

FIG. 6

**Flue Liners.** The first flue liner should be supported along its entire perimeter by masonry. The liner should be bedded in mortar with the joints cut flush and smoothed on the interior and the exterior joint area parged. The flue liners should be set one section ahead of the chimney brickwork.

**Flashing.** Base flashing and counter flashing are installed at the chimney/roof interface, see Fig. 7. The base flashing is installed first on the faces of the chimney perpendicular to the ridgeline with tabs at each corner. The flashing should extend a minimum of 4 in. (100 mm) up the face of the chimney and along the roof. Counter flashing is then installed over the base flashing. It is inserted into a mortar joint for 3/4 to 1 in. (19.1 mm to 25 mm) and mortared solidly into the joint. The counter flashing should lap the base flashing by at least 3 in. (75 mm). If the flashing is installed in sections, the flashing higher up the roofline should lap over the lower flashing a minimum of 2 in. (50 mm). All joints in the base flashing and counter flashing should be thoroughly sealed. The unexposed side of any bends in the flashing should also be sealed.

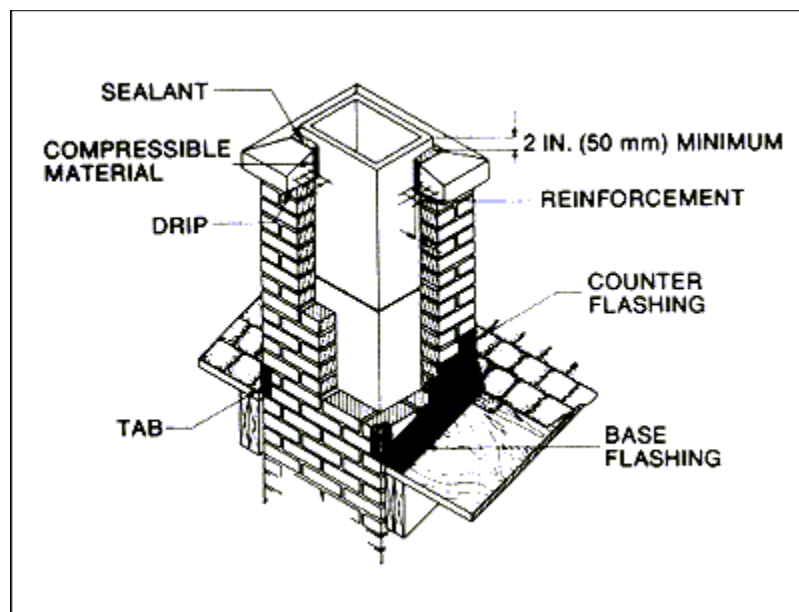

## Typical Section and Flashing Detail

FIG. 7

**Cricket.** If a cricket is desired, usually for chimneys whose dimension parallel to the ridgeline is greater than 30 in. (750 mm) and do not intersect the ridgeline, it should be constructed similar to the one shown in Fig. 8. The dimensions of the cricket are based on the chimney measurements parallel to the ridgeline. The intersection of the cricket and the chimney should be flashed and counter flashed in the same manner as a normal chimney roof intersection. The flashing at the roofline should extend to at least 4 in. (100 mm) under the roofing material. For dimensions and construction details, see Table 4, and Fig. 9.

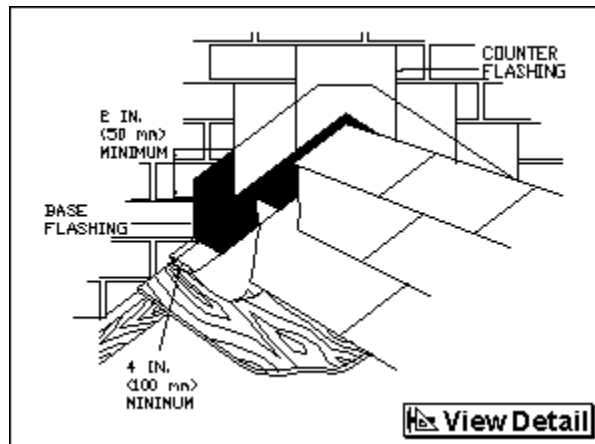

## Typical Flashing Detail

FIG. 8

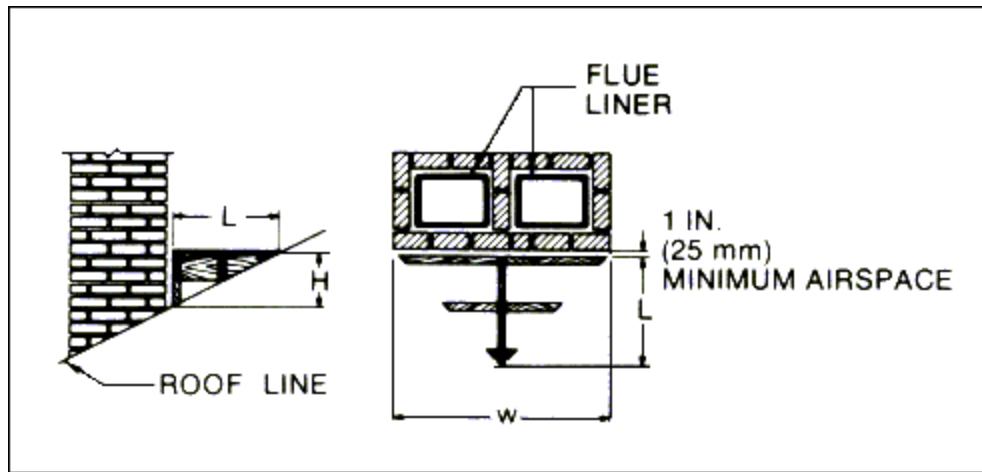

Typical Chimney Cricket Framing

FIG. 9

**Chimney Caps.** There are, as discussed in the materials section, two options regarding chimney caps: 1) prefabricated, and 2) cast-in-place. Prefabricated caps generally provide superior performance as compared to the cast-in-place type. Regardless of which type cap is used, it should be thoroughly primed, backed, and sealed at the cap and flue liner interface to reduce the potential for water penetration.

Prefabricated caps are set in place on a mortar bed. There should be a bond break between the brickwork and the setting bed to allow the cap to respond to the differential movement it will encounter without distressing the brickwork. Figure 3 depicts a typical prefabricated cap. From this figure, general configurations and waterproofing methods may be obtained.

Cast-in-place caps should conform to the shape and minimum dimensions shown in Fig. 3. Feathering the cap to the edge should be avoided since this substantially reduces the thickness at the edge and therefore the potential for deterioration is increased. Waterproofing requirements are different since shrinkage of the concrete as it cures is a certainty. Flashing is highly recommended for cast-in-place caps. The flashing may also be considered as the bond break material. Adequate reinforcement should be placed in the cap to help control cracking due to shrinkage and thermal movements. Additional reinforcement may be necessary in the portion of the cap that overhangs the face of the chimney. Figure 3 shows one method of forming a cast-in-place chimney cap.

When using a chimney cap that does not overhang the face of the chimney, the last two courses of the chimney brickwork should be corbeled out to form a drip to help reduce the amount of water allowed to run down the face of the chimney. The flue liner should extend a minimum of 2 in. (50 mm) above the top of the cap, see Fig. 3.

## Appliance Chimneys

**General.** Fireplace and appliance chimneys have few dissimilarities. The general recommendations for the construction of fireplace chimneys and the proper consideration of three additional components should produce a functional appliance chimney. The three components, either not present in fireplace chimneys or incorporated into the body of the fireplace are: 1) the foundation, 2) the cleanout door, and 3) the thimble.

**Foundation.** The foundation supports the chimney and must be sized to carry all superimposed loads. However, most building codes disallow using the chimney walls as structural elements to support other building components. When designing the foundation, care should be taken to account for soil conditions and type. Undisturbed or well-compacted soil will generally be sufficient, however, some types of soil conditions may require additional analysis.

Building codes generally require that the foundation be at least 12 in. (300 mm) thick, and, in plan view, extend a minimum of 6 in. (150 mm) beyond each face of the masonry bearing on it. It should also penetrate the frost line to reduce the possibility of "heaving" of the foundation while the ground is freezing.

**Cleanout Door.** A cleanout door may not be necessary when venting appliances that use clean burning fuels such as natural gas, however other fuels may produce combustion by-products that will accumulate at the bottom of the chimney and require periodic removal. The cleanout door should be of ferrous metal and set to provide as airtight a seal as possible. If desired, the cleanout door may be oriented toward the interior of the structure, however, the prime consideration in sizing and locating the door is the ease with which it can be used.

**Thimble.** A thimble is the lined opening through the chimney wall that receives the smoke pipe connector, as shown in Fig. 10. A thimble should be set in the chimney at the location of the entrance of the pipe connector. It should be built integrally with the chimney and made as airtight as possible, by using either boiler putty or asbestos cement. The thimble should be set flush with the interior face of the flue liners, and at least 18 in. (460 mm) below the ceiling. The thimble should have a minimum of 8 in. (200 mm) of flue liner extending below its lowest point, see Fig. 10.

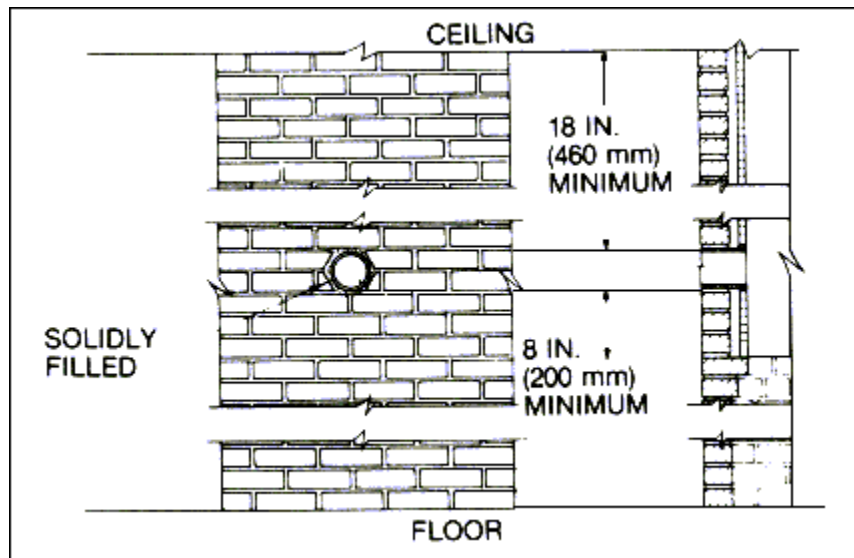

Thimble Detail

FIG. 10

## SUMMARY

This *Technical Notes* has given suggested design and construction methods for residential chimneys. Although, there are differences, both appliance and fireplace chimneys use similar construction techniques and materials. Since the prime function of a chimney is fire safety both quality workmanship and materials should be used.

The information and suggestions contained in this *Technical Notes* are based on the available data and the experience of the Brick Industry Association's technical staff. The recommendations and suggestions are offered as a guide for consideration by the designers, specifiers, and owners of buildings when anticipating the design, detailing and construction of residential chimneys. The final decision to use or not to use these recommendations and materials in brick masonry chimneys is not within the purview of the Brick Industry Association and must rest with the project designer, or owner.

## REFERENCES

1. *One and Two Family Dwelling Code*, published by Building Officials and Code Administrators, Inc., Homewood, Illinois; International Conference of Building Officials, Whittier, California; and Southern Building Code Congress, International, Inc., Birmingham, Alabama.
2. *Book of Successful Fireplaces, How to Build, Decorate and Use Them*, 20th Edition, by R. J. Lytle and Marie-Jeanne Lytle, Structures Publishing Company, Farmington, Michigan, 1977.
3. *How to Install a Fireplace*, by Donald R. Brann, Direction Simplified, Inc., Briarcliff Manor, New York, 1976.
4. *1979 Equipment Volume, ASHRAE Handbook and Product Directory*, by American Society of Heating, Refrigerating and Air-Conditioning Engineers, Inc., New York, New York, 1979.