

Brick Veneer/Steel Stud Walls

Abstract: This *Technical Note* addresses the considerations and recommendations for the design, detailing, material selection and construction of brick veneer/steel stud walls. This information pertains to behavior of the veneer and steel studs, differential movement, anchors, air space, detailing, selection of materials and construction techniques.

Key Words: anchors, brick veneer, design, elastic properties, flashing, masonry, permeability, stability, steel studs, stiffness, walls, weeps.

SUMMARY OF RECOMMENDATIONS:

Veneer Height:

- Maximum veneer height permitted to be supported on foundation is 30 ft (9.14 m) to top of wall or 38 ft (11.58 m) to top of gable unless wall is rationally designed
- Support veneer above this height by shelf angle or other means for each story

Air Space:

- 2 in. (51 mm) minimum air space recommended; 1 in. (25.4 mm) minimum air space required
- 4¹/₂ in. (114 mm) maximum distance required between back of brick veneer and steel framing unless anchors are rationally designed

Flashing:

- Do not stop flashing behind the face of the brickwork
- Place flashing at all points where air space is interrupted
- Extend flashing vertically up the backing to 8 in. (203 mm) minimum height
- Lap flashing to 4 in. (102 mm) minimum height under water-resistant barrier or behind sheathing above grade
- Install base flashing minimum 6 in. (152 mm) above grade
- Turn up flashing ends into head joint a minimum of 1 in. (25.4 mm) to form end dam

Weeps:

- Open head joint weeps spaced at no more than 24 in. (610 mm) o.c. recommended
- Most building codes permit weeps no less than 3¹/₁₆ in. (4.8 mm) diameter and spaced no more than 33 in. (838 mm) o.c.
- Wick and tube weep spacing recommended at no more than 16 in. (406 mm) o.c.

Anchors:

- Corrugated anchors not permitted with steel stud backing
- Minimum W1.7 (9 gage, MW11) adjustable wire anchors, hot-dipped galvanized, two-piece per ASTM A 153 Class B-2
- Minimum one anchor per 2²/₃ ft² (0.25 m²) of wall area (Note: some building codes may require one anchor per 2 ft² (0.19 m²))
- Vertical spacing: maximum 18 in. (457 mm) o.c.
- Horizontal spacing: maximum 32 in. (813 mm) o.c.
- Securely attach anchors to the steel studs through the sheathing, not to the sheathing alone
- For high wind and seismic areas, see Anchors section for anchor placement requirements

Shelf Angles and Lintels:

- Shelf angles located above the height limit (see Veneer Height) may support no more than one story of brick
- Size horizontal leg of all shelf angles and lintels to provide a minimum bearing of 2²/₃ the thickness of the brick wythe

Sheathing:

- Exterior grade gypsum sheathing or OSB or glass fiber mat-faced sheathing or cement board; minimum 1/2 in. (12.7 mm) thick
- Exterior grade plywood; minimum 3/8 in. (9.5 mm) thick
- Closed-cell rigid insulation meeting ASTM C 578 or C 1289; minimum 1/2 in. (12.7 mm) thick

Water-Resistant Barrier:

- Water-resistant barriers include No. 15 asphalt felt, building paper, qualifying high-density polyethylene or polypropylene plastics (housewraps)
- Install water-resistant barrier over sheathing
- Seal water-resistant sheathing per manufacturer to perform as water-resistant barrier
- Ship lap water-resistant barrier pieces minimum 6 in. (152 mm)

Steel Studs:

- Galvanized steel studs with minimum G90 coating
- Restrict allowable out-of-plane deflection of steel studs to L/600 using service level loads
- Minimum 0.043 in. (18 gage; 1.09 mm) studs for exterior walls
- Do not field weld steel studs

Screws:

- Minimum No. 10 self-tapping corrosion-resistant screws with a minimum nominal shank diameter of 0.190 in. (4.8 mm)
- Corrosion resistance provided by polymer coating, zinc plating or stainless steel

Mortar:

- Comply with ASTM C 270
- Type N recommended; Type S alternate

Expansion Joints:

- Provide vertical and horizontal expansion joints through brick veneer
- Design and construct expansion joints complying with recommendations of *Technical Notes* 18 and 18A

Condensation Analysis:

- Determine if potential for condensation exists in the wall
- Make necessary changes to the wall design

PROPERTIES OF BRICK VENEER/STEEL STUD WALLS

Moisture Resistance

Brick veneer construction incorporates a drainage cavity to deter water penetration into the building. This continuous, clean air space creates a physical separation between the brick wythe and the inner steel stud wall. When wind-driven rain penetrates the veneer wythe, the air space allows the water to drain down the back face of the brickwork. This water is then collected by flashing and channeled out of the veneer wythe through weeps. When properly designed and constructed, a brick veneer/steel stud system is a water penetration resistant wall assembly. For additional information regarding water penetration resistance, see the *Technical Notes 7 Series*.

Thermal Performance

Brick veneer systems incorporating an air space can greatly reduce the amount of heat transmission through the system. This air space provides a thermal separation between the brick wythe and other system components, increasing the resistance of the entire wall system to heat loss or gain. Further, brickwork has a high thermal mass giving it the ability to store and slowly release heat over time. This is taken into account in current energy codes by allowing a lower R-value for walls with masonry. Batt insulation is typically placed between studs to increase the thermal resistance of the wall. In addition, closed-cell rigid board insulation can be placed inside an enlarged air space for additional thermal resistance. With the board insulation located outside of the steel stud wall, there is increased resistance to heat transmission and reduced thermal bridging. For further information regarding the thermal resistance of brick assemblies, refer to the *Technical Notes 4 Series*.

Fire Resistance

Brick masonry has superior fire resistance. Building codes may require that exterior walls have a fire resistance rating based on fire separation distance, size of building and occupancy classification. Exterior walls may require protection from one or both sides, depending on whether the fire separation distance is more or less than 5 ft (1.52 m), respectively. A nominal 4 in. (102 mm) brick wythe has a 1 hour fire resistance rating and can provide this protection for the exterior surface of the wall. For fire resistance from inside the building, the steel stud must be protected on the interior side. Fire-rated gypsum board is typically used for this purpose and can be layered to provide the required rating. For additional information, see the *Technical Notes 16 Series*.

Acoustics

Brick veneer walls with cavities are well suited as sound insulators. Three mechanisms reduce the sound transmitted through the wall. The hard surface of the brickwork reflects a large portion of sound waves. The mass of the brickwork absorbs another portion of sound energy. The remaining sound energy which makes its way through the brick wythe must continue through the air space and the sheathed studs. This air space separates the brick from the steel studs causing a dampening effect. With only anchors bridging the air space, a further reduction in sound wave propagation is realized due to discontinuous construction. Finally, the energy must vibrate the sheathing and stud to reach the inside of the building. Additional information on sound transmission can be found in *Technical Note 5A*.

Aesthetics

Brick is available in a large variety of colors, textures, glazes and coatings. In addition, many sizes are manufactured and special shapes can be created to achieve a broad range of units. Add to this the ability to achieve multiple bond patterns, the use of colored mortars and interesting masonry detailing, and the creative possibilities are nearly endless. For further information on sizes and patterns, refer to *Technical Notes 10B and 30*.

Ease of Construction

The steel studs and exterior sheathing of a brick veneer/steel stud wall can be constructed prior to laying the brick veneer wythe. This allows the building to be closed-in and placed under-roof quickly. Thus, interior work can begin with brick masonry construction following at a convenient time. Further, other trades can be scheduled to work and not interfere with the mason. Care should be taken to ensure that the stud system is not compromised prior to installation of the brickwork.

Design Weight

The weight of a brick veneer/steel stud wall is less than a wall constructed of brick and concrete masonry units. Thus perimeter framing member sizes and seismic forces used in the design may be reduced.

INTRODUCTION

The brick veneer/steel stud wall system offers several advantages over other claddings. The system demonstrates superior performance in many of the specific areas of concern for designers, contractors and property owners such as attractive appearance, high resistance to water penetration, low thermal transmission rate, ease of construction and low maintenance. Introduced in the 1960's, the brick veneer/steel stud wall system has evolved into a successful construction method used in a wide variety of commercial, industrial and institutional structures which include such building types as churches, hospitals and office buildings. These buildings usually have structural frames of steel or reinforced concrete. Unlike residential construction, they generally are not designed with overhangs, eaves or gutters to protect the veneer and frequently incorporate parapets. They also are usually taller than residential structures. Consequently, many commercial brick veneer/steel stud wall systems have greater exposure to their environment than their residential counterparts. For this reason, it is important to closely observe proper design, detailing and construction practices to ensure that expected and required levels of performance are met.

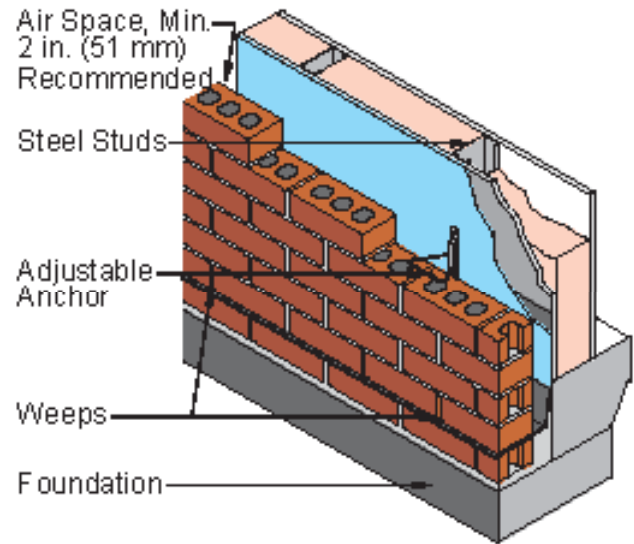

Figure 1
Brick Veneer/Steel Stud Wall

The brick veneer/steel stud wall system is considered an anchored veneer wall. An anchored veneer is a brick wythe secured to and supported laterally by the backing through anchors and supported vertically by the foundation or other structural elements. The veneer transfers out-of-plane load directly to the backing and is not considered to add load-resisting capacity to the wall system. Anchored brick veneer with steel stud backing consists of a nominal 3 or 4 in. (76 to 102 mm) thick exterior brick wythe mechanically attached to a steel stud backing system with corrosion-resistant metal anchors so as to create a prescribed air space between the veneer and the backing system as shown in [Figure 1](#).

This *Technical Note* is one in a series dealing with brick veneer. This *Technical Note* addresses brick veneer with steel stud backing in commercial construction. Others in the series discuss other types of brick veneer wall systems.

STRUCTURAL DESIGN CONSIDERATIONS

Brick veneer/steel stud walls must resist loads as prescribed by the governing building code(s). For exterior, nonbearing walls, these loads are typically due to wind and seismic events. Although a veneer is defined as a nonstructural facing, brick veneer does resist loads. Certainly the weight of the brick is supported by the brickwork itself. But brickwork also contributes to the resistance of out-of-plane loads generated by wind and seismic events. In addition, in-plane forces caused by the weight of the brickwork are also resisted internally, including in-plane loads generated by seismic events. Returns and offsets in the veneer wythe can also act as flanges (in the absence of expansion joints at these locations) and cause in-plane loads on the wall. Steel studs can be designed to be nonloadbearing or loadbearing. Both nonloadbearing and loadbearing studs provide backing for the brick wythe by resisting any out-of-plane loads such as those from wind or seismic events. Loadbearing studs also serve as part of the structural system of a building by supporting a portion of the gravity load or acting as shear walls while nonloadbearing studs only support their own weight.

Minimum standards for brick veneer/steel stud walls are established in the model building codes adopted by most local jurisdictions. Some of these codes reference the ACI 530/ASCE 5/TMS 402 *Building Code Requirements for Masonry Structures*, also known as the Masonry Standards Joint Committee (MSJC) Code. [Ref. 2] Within this Code, there is an entire chapter devoted to masonry veneers which outlines prescriptive, as well as alternate design requirements, for anchored masonry veneers. To determine code provisions for a building in a specific area, the local building code jurisdiction should be consulted.

System Behavior

Together, brick veneer and steel studs resist out-of-plane loads by each taking a portion of the load relative to its flexural stiffness, span length, and the ability of the anchors to transfer the load. The flexural stiffness of the brick is substantially greater than that of the steel stud backing. In addition, the brick veneer typically spans a greater distance than the steel stud system as shown in [Figure 2](#). Consequentially, the brick initially carries most of the load, acting similar to a one-way beam. Deflections in the brick wythe are transmitted to the steel studs through the anchors. Anchors nearest the top and bottom of the steel stud transfer more load than those located near the center of the span. Frictional forces at the support for the veneer resist a portion of the load.

As the masonry continues to deflect, flexural tensile stresses developed in the veneer may cause a break in bond near the point of highest moment, typically near the center of the brickwork. This occurs when the modulus of rupture of the brickwork has been exceeded. The veneer will subsequently act as two separate segments with no stress transfer across the crack. Thus, each segment will act as a one-way beam spanning between the anchor nearest the crack and the respective anchor at the top or bottom of the veneer.

Steel Stud Deflection Criteria

Steel studs must be designed to provide adequate out-of-plane support for all loads imposed on the wall system. This is done by establishing a maximum deflection limit on the stud while maintaining steel stress values in the stud within permissible limits. This deflection is calculated assuming the entire out-of-plane load is resisted by the studs alone, neglecting contribution of the brick veneer. While a number of design tables are based on a stud deflection of stud span length divided by 360 ($L/360$), using this criterion may permit more deflection than the veneer is able to tolerate. Therefore, to obtain sufficient backing stiffness, the allowable out-of-plane deflection of the studs due to service level loads should be restricted to $L/600$. Such deflection criterion will allow a maximum crack width of about 0.015 inches (0.38 mm) in the brick veneer wythe for typical floor-to-floor dimensions.

Steel Stud Design Recommendations

Studs surrounding all openings in the veneer should be designed with loads based on the tributary area of the opening (windows and framing must be tied only to the metal studs). Further criteria for loadbearing studs include providing adequate bearing capacity for the gravity loads. The flanges of the steel studs must be laterally braced to resist compression in bending. This can be accomplished by fastening sheathing or board materials, such as water-resistant gypsum sheathing, plywood or cement board, to each side of the stud. In general, rigid board insulation does not contribute to adequate bracing. Alternatively, if sheathing or board materials are only installed on the exterior side of the stud, bracing can be provided by attaching engineered steel straps or channels affixed either horizontally or diagonally to the studs. However, it is suggested to provide sheathing on both sides, in addition to any engineered bracing, to help support the water-resistant barrier and any interior finishes. The design of the bracing should follow appropriate codes and technical literature. [Ref. 8]

Seismic and Wind Requirements

The following requirements apply to all anchored veneer, not exclusively those with a backing of steel studs. For further information, refer to *Technical Note 3*.

Seismic Requirements. As with all building materials, when the possibility and potential intensity of seismic activity increases, certain brick veneer seismic provisions are invoked. These requirements are specified in the model

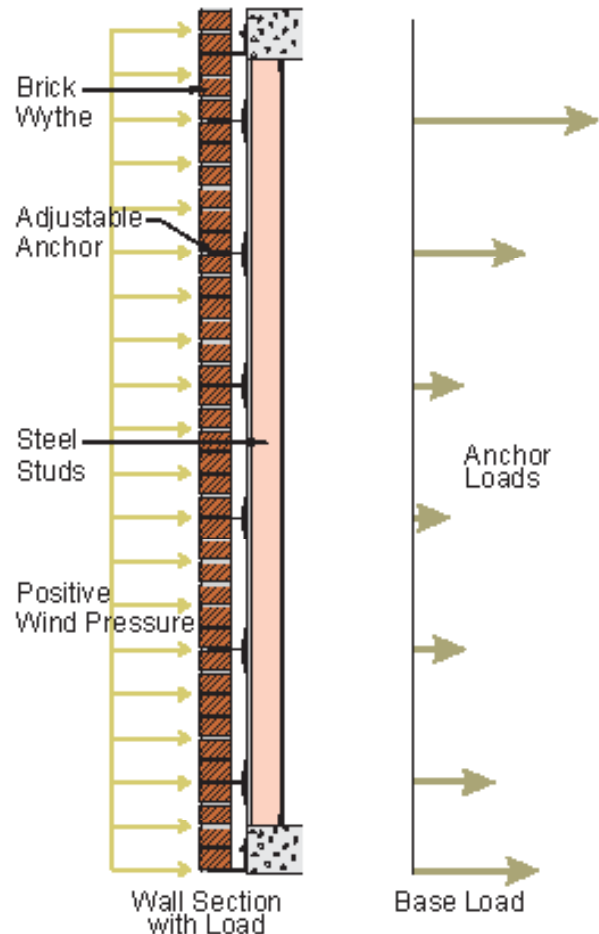

Figure 2
Initial Moment and Anchor Load Distribution

building codes. Some of these codes reference the MSJC Code. Refer to the appropriate building code to determine specific seismic provisions.

The veneer chapter of the MSJC Code addresses seismic provisions for anchored masonry veneers. Beginning in Seismic Design Category (SDC) C, these requirements become increasingly more stringent as the SDC increases. The veneer is first required to be isolated from the structure. It is then required to have a reduced spacing of anchors. Finally, joint reinforcement that is mechanically attached to the anchors is required. [Ref. 2]

Wind Requirements. In locations where the basic wind speed exceeds 110 mph (177 km/hr) but does not exceed 130 mph (209 km/hr) and the building's mean roof height is not greater than 60 ft (18.3 m), the permissible wall area per anchor is required to be reduced and the spacing between anchors at perimeter openings must be reduced. In locations where the basic wind speed exceeds 130 mph (209 km/hr), the veneer is permitted to be rationally designed. [Ref. 2]

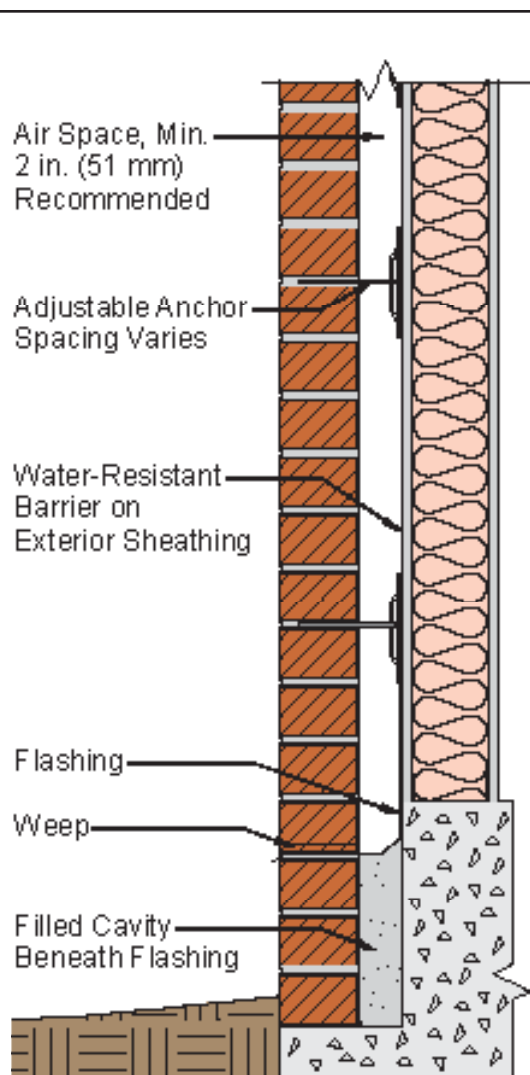

Figure 3
Wall Section at Foundation

DETAILING

Foundations

Although some building codes permit the support of brick veneer on wood foundations, it is recommended that the weight (gravity load) of the veneer be supported on concrete or masonry foundations or other noncombustible structural supports, such as attached steel angles. The brick wythe may extend below grade if it is properly detailed and constructed to minimize water penetration. A typical foundation detail is shown in [Figure 3](#). Locating base flashing and weeps a minimum of 6 in. (152 mm) above grade will allow the drainage system to function properly. Base flashing should extend through the full wythe of the veneer to the exterior to preclude any moisture from migrating by capillary action up through the brickwork.

Brickwork below the base flashing should be detailed as a barrier wall system by completely filling the cavity or air space with grout or mortar to minimize water penetration. Anchors should be located within the grout-filled cavity according to the same spacing as in the brick veneer above grade. Steel studs should be located a minimum of 6 in. (152 mm) above grade and should not be used below grade on exterior walls under any circumstances.

If soil immediately adjacent to the brickwork is not free-draining the brick wythe exterior should be waterproofed below grade. Self-adhesive waterproofing membranes with protection board to prevent damage during backfill operations can prevent water from penetrating the brick. Drainboards with integral filter fabric and waterproofing membrane can also be installed to drain water to the foundation drain tile system. A French drain between the soil and the wall, consisting of a gravel fill with a fabric filter surround and drain tile below, sloped a minimum of $\frac{1}{8}$ in./ft (10 mm/m) can also provide some drainage. Finished grade should provide positive drainage by sloping away from the wall.

Water-Resistant Barrier

Water-resistant barriers are membranes which prevent liquid water from passing through them. These are different from vapor retarders, intended to prevent water vapor diffusion, and air barriers, intended to prevent air flow through the wall system. Such a membrane should be located between the air space and the sheathing or between the rigid insulation and the sheathing. A water-resistant barrier should keep out any water which finds its way across the air space via anchors, mortar bridging or splashing. Individual pieces of water-resistant barrier should be installed with their edges and ends lapped at least 6 in. (152 mm). While a separate membrane is pre-

ferred, sheathing or rigid insulation with an inherent resistance to moisture penetration may also serve as a water-resistant barrier when all edges and joints are completely taped or sealed.

A water-resistant barrier is required and can be provided by No. 15 asphalt felt, building paper, qualifying high-density polyethylene or polypropylene plastics (housewraps) and qualifying water-resistant sheathings when properly sealed. No. 15 asphalt felt should comply with Type I of ASTM D 226, Specification for Asphalt-Saturated Organic Felt Used in Roofing and Waterproofing. Asphalt felt should not be left exposed to ultraviolet (UV) light for an extended period of time, otherwise, it will lose the asphalt saturation and water resisting characteristics.

Some plastic membranes (housewraps) may have qualities similar to those of a water-resistant barrier, but ascertaining the effectiveness of a particular plastic as a water-resistant barrier can be difficult. While felts tend to seal themselves when penetrated by fasteners, plastics may not. In addition, some plastic membranes also act as vapor retarders and hence can potentially trap water vapor inside the stud wall where it can condense if the temperature gradient in the wall drops below the dew point. The length of time a plastic membrane will be exposed to sunlight should also be considered. Most show serious degradation with 3 to 12 months exposure to UV rays. Thus, all plastic membranes should not be regarded as equivalent and caution should be used when using them as a water-resistant barrier.

Care should be taken to reduce the likelihood of tearing the membrane or breaking the barrier. Such tears or breaks must be corrected prior to installation of brickwork. Water-resistant sheathings with integral membranes must be completely sealed with compatible tape or sealant to perform as water-resistant barriers. This means components providing this seal must maintain their integrity and performance when subjected to moisture and other environmental conditions over the life of the wall. These sheathing systems should also allow for the transmission of vapor unless the effect of a vapor retarder is considered at this location in the wall.

Sheathing

An exterior grade sheathing or insulation material should be installed on the exterior side of the stud. Edges and joints of sheathing or insulation board that also serve as the water-resistant barrier should be thoroughly sealed with compatible tape or sealant to ensure against moisture intrusion over the life of the wall. Such joint treatment will also reduce air infiltration. Careful detailing at the top of walls, at transition to other opaque materials and at window openings should provide a watertight condition. If sheathing is used to laterally brace the studs, it should be rigid enough to provide the required stiffness.

Exterior sheathing on steel studs should be suitably fastened with corrosion-resistant screws. The sheathing should be one of the following: exterior grade gypsum sheathing or glass fiber mat-faced sheathing or cement board, not less than 1/2 in. (12.7 mm) in thickness; closed-cell insulating rigid foam not less than 1/2 in. (12.7 mm) thick conforming to ASTM C 578 or ASTM C 1289 or oriented strand board (OSB) not less than 1/2 in. (12.7 mm) in thickness; or exterior grade plywood not less than 3/8 in. (9.5 mm) in thickness.

Screws

Corrosion-resistant screws with a minimum nominal shank diameter of 0.190 in. (4.8 mm) are required to attach anchors to steel studs. A minimum #10 self-tapping screw is recommended. Screws used to attach exterior sheathing and anchors can be either carbon steel or stainless steel. Carbon steel screws should have a non-corrosive coating of zinc, polymer or composite zinc-polymer. Zinc-plated screws should be either mechanical-zinc plated according to either 1) ASTM B 695, Specification for Coatings of Zinc Mechanically Deposited on Iron and Steel or 2) electro-zinc plated in accordance with ASTM B 633, Specification for Electrodeposited Coatings of Zinc on Iron and Steel. Polymer-coated screws do not have the self-healing properties of zinc, however they can offer acceptable, long-term protection. A composite zinc-polymer coating offers superior protection to either coating alone. Stainless steel screws may be acceptable even though a galvanic potential exists between stainless steel and carbon steel. This is possible because of an area-relationship principle where the surface area of the steel stud is much larger than that of the screw which results in a decreased corrosion potential. Copper-coated screws are not recommended since they can react galvanically with steel studs having zinc coatings.

Screws incorporating an integral EPDM or neoprene sealing washer under the screw head may also assist in water penetration resistance. Due to the area-relationship principle mentioned above, when stainless steel screws are used with carbon steel anchors, sealing washers are highly recommended.

Steel Studs

The top connection of nonbearing studs must be detailed to prevent inadvertent vertical load transfer to nonload-bearing studs. No rigid connection should be allowed between the top track and the studs. This allows for the structural member above the track to deflect without transferring loads to the studs. Field welding of studs should not be permitted. Shop welding may be permitted on steel studs with a minimum nominal thickness of 0.068 in. (1.7 mm) (14 gage) studs. To increase quality assurance, welders and welding procedures should be qualified as specified in AWS D1.3 by the American Welding Society. A corrosion inhibiting coating should be applied to all welded areas after welding is completed.

Steel studs should have a minimum nominal thickness of 0.043 in. (1.1 mm) (18 gage) to provide sufficient thickness to engage the threads of the screw. Studs should have a protective coating conforming to one of the following ASTM standards: 1) ASTM A 653/653M, Specification for Steel Sheet, Zinc-Coated (Galvanized) or Zinc-Iron Alloy-Coated (Galvannealed) by the Hot-Dip Process with a minimum G90/Z275 coating designation or 2) ASTM A 875/875M, Specification for Steel Sheet, Zinc-5% Aluminum Alloy-Coated by the Hot-Dip Process with a minimum GF90/ZGF275 coating designation. For further information on selecting corrosion inhibiting coating weight, refer to *GalvInfoNote #19* [Ref. 4]

Air Space

The air space or drainage cavity provides a means to drain water which penetrates the brick veneer. The air space between the back of the brickwork and the sheathing or rigid board insulation is recommended to be a minimum of 2 in. (51 mm) and required to be a minimum of 1 in. (25.4 mm) in order to minimize the possibility of mortar bridging the air space. A 4½ in. (114 mm) maximum distance is required between the back of the brick wythe and the steel framing unless the anchors are rationally designed. If this distance is exceeded, additional or stronger anchors may be required. Insulation must be attached to the backing by mechanical or adhesive means to keep it from blocking the air space. When a high probability of mortar falling into the air space exists, such as for tall brick veneer without shelf angles, drainage materials that catch mortar droppings may be specified at the base to prevent mortar blocking the weeps. However, the use of drainage materials should not preclude good workmanship and an effort to keep the air space clean of excess mortar droppings.

Flashing

Flashing collects water at the bottom of the air space and directs it toward weeps which channel it to the exterior face of the wall. Flashing must be placed at all locations where the air space is interrupted. These include above and below all window and wall openings, above all shelf angles, at the base of the wall and under the coping at parapets. Flashing should extend vertically up the backing a minimum of 8 in. (203 mm). If drainage materials that catch mortar are placed at the bottom of the air space, flashing at the base of the wall may need to extend further up the backing. This ensures that the flashing extends above the height of the drainage material and helps deter water that migrates across mortar on the drainage material from entering the backing. The water-resistant barrier on the backing should lap the top of the flashing a minimum of 4 in. (102 mm). Individual flashing pieces should be lapped at least 6 in. (152 mm) and sealed to avoid water running under adjacent flashing pieces. Where flashing is discontinuous, such as over and under openings in the wall, the ends should be turned up at least 1 in. (25.4 mm) into the next head joint to form an end dam to channel water out of the wall. When possible, flashing should extend beyond the face of the brickwork to form a drip. When using a flashing that deteriorates with UV exposure, a metal or stainless steel drip edge can accomplish this. It is imperative that flashing be extended at least to the face of the brickwork.

Flashing material should be waterproof and durable. It should be sufficiently tough and flexible so as to resist puncture and cracking. In addition, flashings subject to deterioration from UV light should not be overly exposed to sunlight. Flashing should not deteriorate when in contact with metal parts, mortar, sealants or water. Flashing should also be compatible with adjacent adhesives and sealants. Flashings used in a wall system with water-resistant sheathing acting as the water-resistant barrier should be self-adhesive or be mechanically attached with a pressure bar and sealant. It is suggested that only superior flashing materials be selected, since replacement in the event of failure is extremely expensive.

Weeps and Vents

Weeps should be placed immediately above the wall flashing to permit water to exit the wall. Open head joint weeps are recommended with a spacing of no more than 24 in. (610 mm) on center. Wick and tube weeps are

recommended to be spaced no more than 16 in. (406 mm) on center. Most building codes require weep openings to have a minimum diameter of $\frac{3}{16}$ in. (4.8 mm) and allow weeps to be spaced up to 33 in. (838 mm) on center. Wicks should be at least 16 in. (406 mm) long and extend through the brick into the air space and along the back of the brick. Non-corrosive metal, mesh or plastic screens can be installed in open head joint weeps if desired.

Vents (open head joints) may be placed at the top of the drainage air space to help reduce moisture buildup in the air space by promoting ventilation. Vents should be spaced at the same horizontal spacing as weeps and should be centered between weeps. Insect access to vents may be controlled through the use of covers or screens.

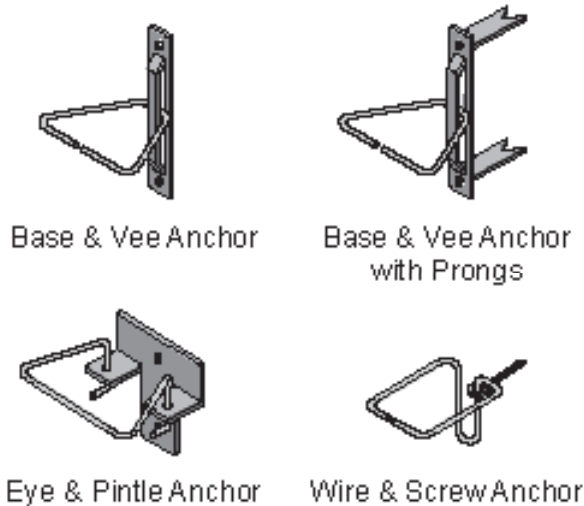

Figure 4
Adjustable Anchor Assemblies

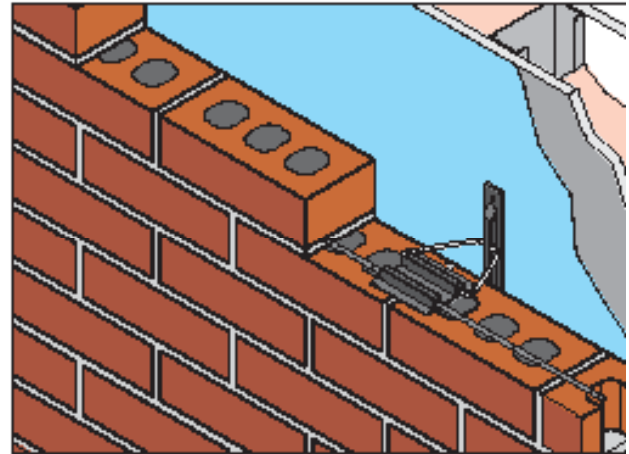

Figure 5
Seismic Anchor Assemblies

Anchors

Care must be taken to anchor the masonry veneer to the backing in a manner that will permit each to move freely, in-plane, relative to the other. Anchors that connect the veneer to the backing must provide out-of-plane support, resisting tension and compression, but allowing shear. This permits in-plane differential movement between the frame and the veneer without causing cracking or distress. Such anchors are shown in [Figure 4](#). Corrugated anchors are not permitted when brick veneer is anchored to steel stud backing.

Anchors should provide the capacity to transfer loads applied to a maximum of $2\frac{2}{3}$ ft² (0.25 m²) of wall area. Each anchor should be spaced a maximum of 18 in. (457 mm) on center vertically and a maximum of 32 in. (813 mm) on center horizontally. They must be securely attached through the sheathing to the steel studs, not to the sheathing alone. Around the perimeter of openings, additional anchors should be installed at a maximum of 3 ft (914 mm) on center within 12 in. (305 mm) of the opening.

All anchors must be embedded at least $1\frac{1}{2}$ in. (38 mm) into the brick veneer with a minimum mortar cover of $\frac{5}{8}$ in. (15.9 mm) to the outside face of the wall. Anchors in Seismic Design Categories E and F must be mechanically fastened to horizontal reinforcement in the brick veneer as depicted in [Figure 5](#).

Anchors transfer load between the brick veneer and either the studs or the structural frame of the building. The load that is transferred through a particular veneer anchor depends on many factors. Such factors include: anchor stiffness; air space dimensions; the backing element the anchor is fastened to (the building frame or the steel stud); where the anchor is fastened relative to the backing element's span; where the anchor is located relative to the brick veneer's span; whether any cracks have occurred in the veneer; stud stiffness; and embedment.

For walls having shelf angles at each floor level, with either no windows or punched window openings in which brick veneer supports the lintel, anchors carrying the highest load will be located near the bottom and top of the floor span that are attached directly to the building frame. In one test performed for this configuration, the anchor connected closest to the shelf angle supporting the veneer carried just over 30% of the total out-of-plane load of the vertical strip on the story it served. [Ref. 1]

With brick veneer supported on a shelf angle above a window band, the anchors at the floor level will typically carry the highest load. Again, anchors which are fastened directly to the building frame will carry more load than

those attached to the studs.

Anchors are required to be made of carbon steel or stainless steel. Carbon steel anchors are required to conform to ASTM A 82. Stainless steel anchors are required to conform to ASTM A 580. Anchors made of carbon steel are required to be hot-dipped galvanized in accordance with Class B-2 of ASTM A 153/153M, Specification for Zinc Coating (Hot-Dip) on Iron and Steel Hardware.

Two-piece adjustable anchors with a minimum wire size of W1.7 (MW11) are required. Eye and pintle adjustable anchors are required to have a minimum wire size of W2.8 (MW 18) with a diameter of $\frac{3}{16}$ in. (4.8 mm). Wire anchors are available in a variety of standard lengths from 3 to 5 in. (76 to 127 mm) and diameters from 0.15 to 0.25 in. (3.7 to 6.4 mm). In addition, anchors should have a maximum horizontal out-of-plane mechanical play of $\frac{1}{16}$ in. (1.6 mm) and should be detailed to prevent disengagement.

Anchors with formed drips in the wire should not be used since they have reduced load capacity. Corrugated anchors are not permitted with steel stud backing. They may not fully engage the stud upon initial loading and do not have sufficient compressive capacity for the given air space.

Anchors incorporating an EPDM sealing membrane between the sheathing or insulation and the wall base of the anchor should be considered for superior water resistance. Prongs at each end of an adjustable anchor base, as shown in [Figure 4](#), may also be considered with non-rigid sheathing to provide a mechanical connection between the anchor and the stud. These prongs provide positive, independent anchorage in the event of long-term deterioration of sheathing or insulation and prevent compression of the insulation or sheathing. When using a prong-leg base, a modified asphalt pad with self-adhesive is recommended. This pad is installed under the anchor base and will seal openings created by the prongs and screws in the sheathing or insulation.

Lintels and Shelf Angles

Lintels provide support of brickwork over masonry openings by bearing on the brickwork on each side of the opening. They are not attached to the building structure. Shelf angles provide support for the brickwork above by attaching to the building structure. Shelf angles are at times referred to as relieving angles.

Steel for lintels and shelf angles should conform to ASTM A 36/A 36M, Specification for Carbon Structural Steel. Steel angles should be a minimum of $\frac{1}{4}$ in. (6.4 mm) thick. All angles should be primed and painted as a minimum to inhibit corrosion. Galvanized and stainless steel angles should be considered in harsh environments such as coastal areas.

Lintel and shelf angle deflection between support points should not exceed the lesser of $L/600$ or 0.3 in. (7.6 mm) and the total rotation of the toe of the angle should be less than $\frac{1}{16}$ in. (1.6 mm). The horizontal leg of all angles should be sized to support a minimum of $\frac{2}{3}$ the thickness of the brick wythe.

Lintels should be installed over all masonry openings unless the brick is self-supporting. Lintels can be loose steel angles, stone, precast concrete or reinforced masonry. They should bear a minimum of 4 in. (102 mm) on brick on each side of the opening and should be sized to carry the brick veneer above them. For further information on lintels, refer to *Technical Note 31B*.

Vertical expansion joints should not cross a lintel without making provisions for potential movement. When an expansion joint crosses a lintel, the full weight of the brickwork above the lintel must be carried by the lintel.

Shelf angles should consist of steel angles sized and installed to carry the brickwork above. Structures with a maximum veneer height of 30 ft (9.14 m) from foundation to top of wall and 38 ft (11.58 m) from foundation to top of gable can have their entire brick veneer supported directly on a foundation wall, footing or noncombustible support without shelf angles. Unless rationally designed, brick veneer above this height is required to be supported by shelf angles for each story. Shelf angles are typically located near the floor line or at the window head. Shelf angles attached to rigid concrete or steel elements should

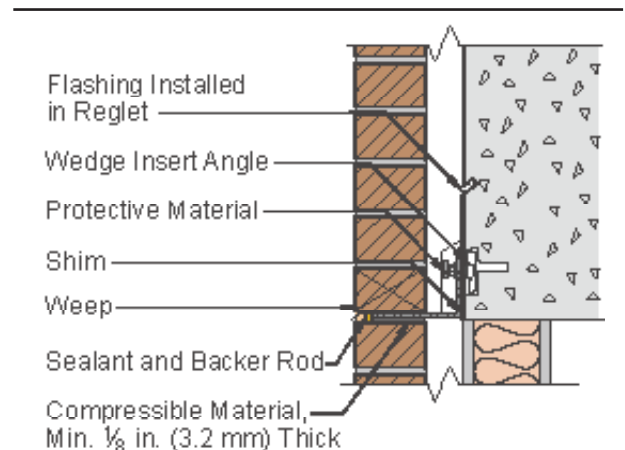

Figure 6
Shelf Angle with Concrete Frame

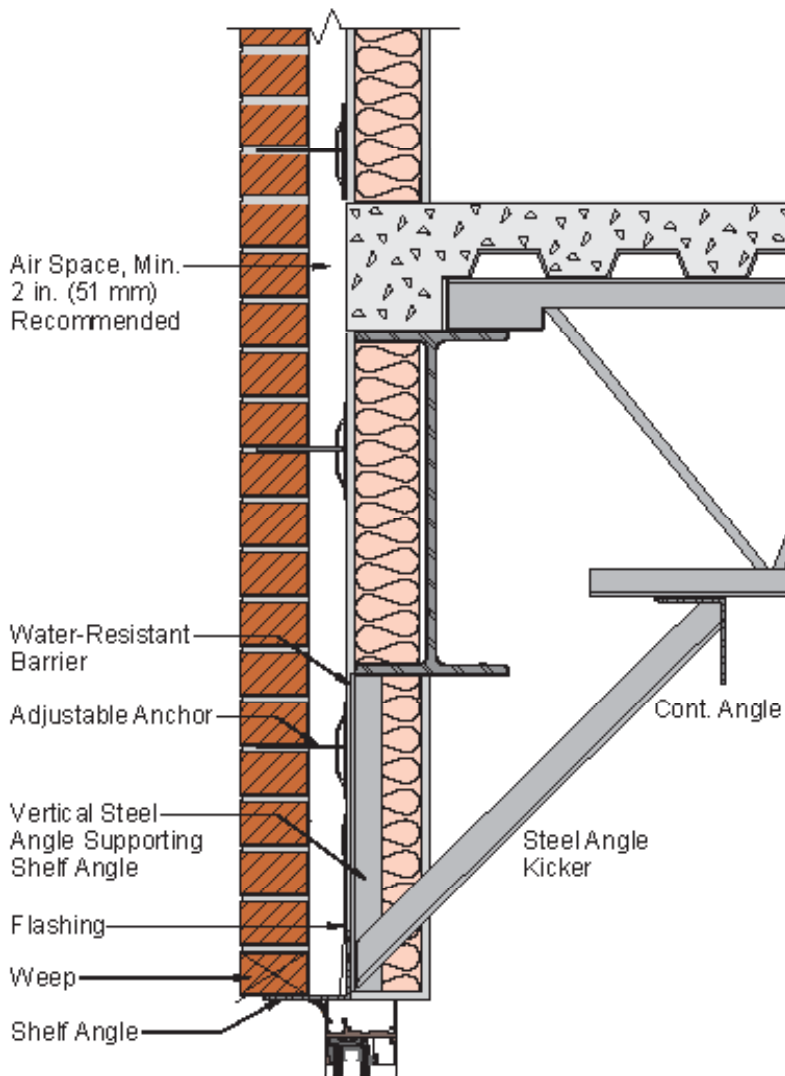

Figure 7
Brick Veneer/Steel Stud Bracing System

have full height shims to reduce rotation as shown in Figure 6. Any shelf angle attached to miscellaneous steel elements must have bracing to prevent out-of-plane movement of the wall as depicted in Figure 7.

Shelf angles should not be installed as one continuous member. Space should be provided at intervals to permit thermal expansion and contraction of the steel angle to occur without causing distress to the masonry. Lipped brick may be used above or below a shelf angle to maintain the same joint width at the angle as other joints in the brickwork.

Shelf angles should be supported by miscellaneous structural steel elements and not by steel studs. Field welding of shelf angles to studs should never be permitted since the thin wall of the steel stud increases the potential for burn-through. Further, a stud which supports a shelf angle may require additional reinforcing and may be more prone to corrosive action from exposure to the moist air space.

Head, Jamb and Sill Details

Openings in brick veneer walls should be carefully detailed to prevent water from entering the brick veneer/steel stud wall system. Provision should be made for movement between the brick veneer and the frame or backing. Window frames, door

frames and opening sleeves must be attached to the backing, not the brick veneer. Window and door flashing must be integrated with the water-resistive barrier to provide a continuous barrier to moisture intrusion as shown in Figures 7 and 8. Sills should be sloped to the outside for drainage. Refer to *Technical Note 36* for further information.

Sealant Joints

Sealant joints prevent water penetration at expansion joints and perimeters of openings. These joints are typically a compressible, foam backer rod recessed and covered by a sealant. Sealant joints should be free of mortar for the entire thickness of the brick veneer and closed with the backer rod and sealant. If desired, a compressible material may be included behind the backer rod.

The perimeter of all exterior window frames, door frames and sleeves should be closed with a sealant joint as shown in Figure 8. This joint should be between $\frac{1}{4}$ and $\frac{1}{2}$ in. (6.4 and 12.7 mm) wide and $\frac{1}{4}$ in. (6.4 mm) deep. Fillet joints are not recommended, but if used, should be at least $\frac{1}{2}$ in. (12.7 mm) across the diagonal.

Sealants should be selected for their durability, extensibility, compressibility and their compatibility with other materials. A sealant should be able to maintain these qualities under the temperature extremes of the climate in which the building is located. Sealant materials should be selected to comply with ASTM C 920, Specification for Elastomeric Joint Sealants. Specific sealants recommended for brick include polysulfide, solvent release acrylic, silicone and urethane sealants. A sealant primer may be required before applying some sealants on certain brick to preclude staining. Since acetoxenic silicone will attack cement in mortar, it should not be applied to masonry. Oil-based caulks should not be used since they may stain the adjacent brickwork. Refer to Figures 6 and 11. For

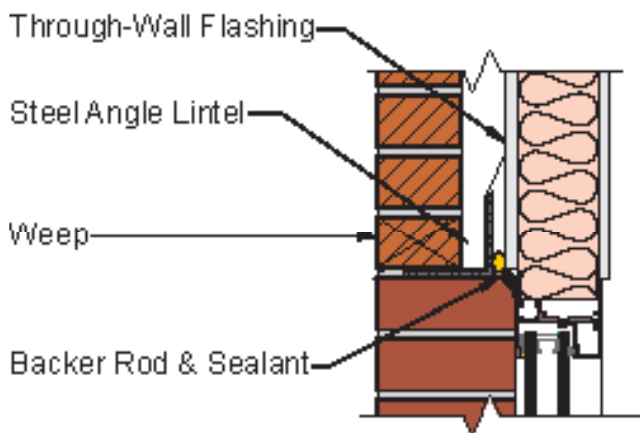

a) Window Head Detail

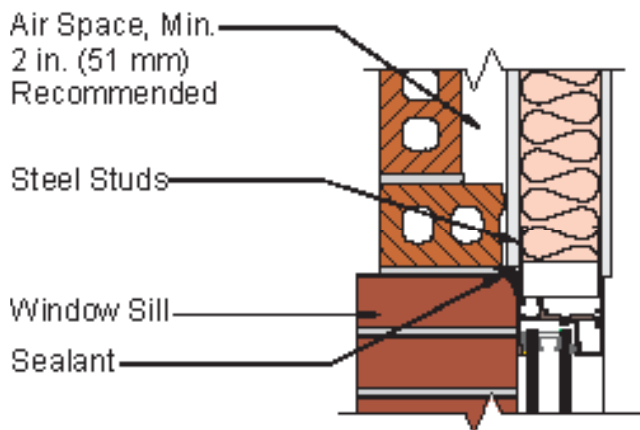

b) Window Jamb Detail

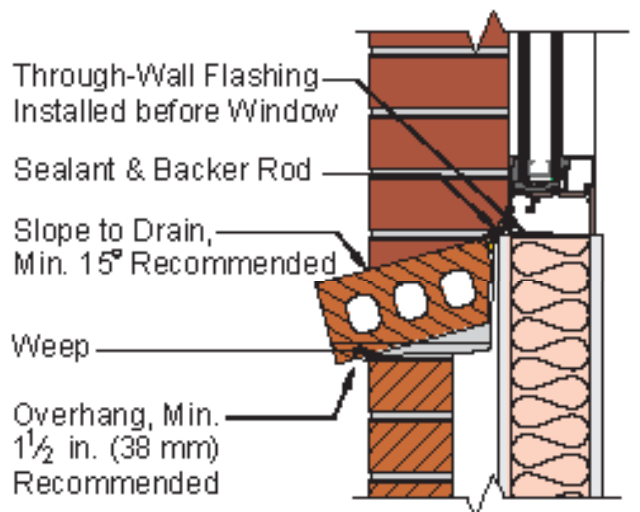

c) Window Sill Detail

Figure 8
Window Details

further information on sealants, refer to ASTM C 1193, Guide for Use of Joint Sealants.

Backer rods should be placed behind all sealant joints. They should be of closed-cell plastic foam or sponge rubber. Backer rods should be capable of resisting permanent deformation before and during sealant application, non-absorbent to liquid water and gas, and should not emit gas which may cause bubbling of the sealant. A bond breaking tape may be required with some types of backer rods.

Parapet Walls

Parapets are exposed on three sides and consequently are potentially more vulnerable to water penetration and condensation. Parapet walls should be avoided unless required. If a parapet is required, it should be properly designed, detailed and constructed. Steel studs are not recommended as backing for parapet walls because of potential moisture and movement issues. Reinforced masonry provides the best means of constructing parapets above brick veneer/steel stud walls as shown in [Figure 9](#). A gravel stop detail as shown in [Figure 10](#) can be used instead of a parapet wall.

OTHER CONSIDERATIONS

Condensation

Experience has shown that most water or moisture found between steel studs in a brick veneer/steel stud wall can be attributed to condensation. Condensation occurs at the point in the wall where the temperature gradient exceeds the dew point. If this point is within the air space, then the condensation will find its way out of the wall via the drainage system. However, if it is on the inside of the steel stud wall with batt insulation, then it may dampen or eventually saturate the surrounding materials and may lead to mold and/or corrosion problems.

Consequently, it is recommended that a condensation analysis be conducted to determine if the potential for condensation exists in a wall. If results indicate that it may occur within the sheathing or steel stud wall, then the wall design should be changed. Rigid board insulation may be placed on the outside of the exterior sheathing to increase the thermal resistance of the wall or an air barrier or vapor retarder may be installed to decrease air and vapor movement through the wall. Installing some or all of the required insulation in the air space also helps reduce or eliminate thermal bridging through the steel studs. See *Technical Notes 7C and 7D* for further information.

Air Barriers and Vapor Retarders

Where analysis indicates a probability of condensation, an air barrier or vapor retarder should be provided. Air

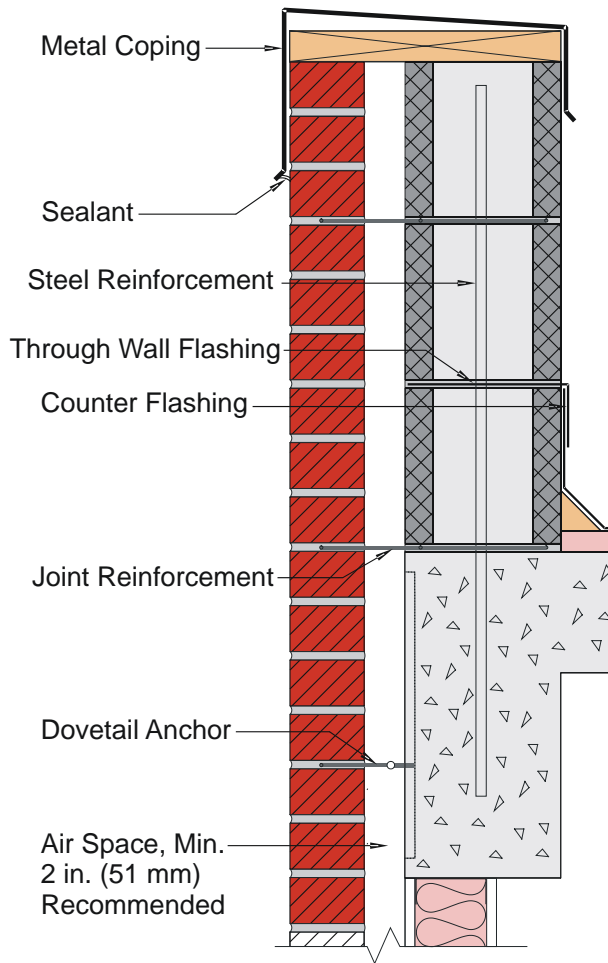

Figure 9
Masonry Parapet Wall

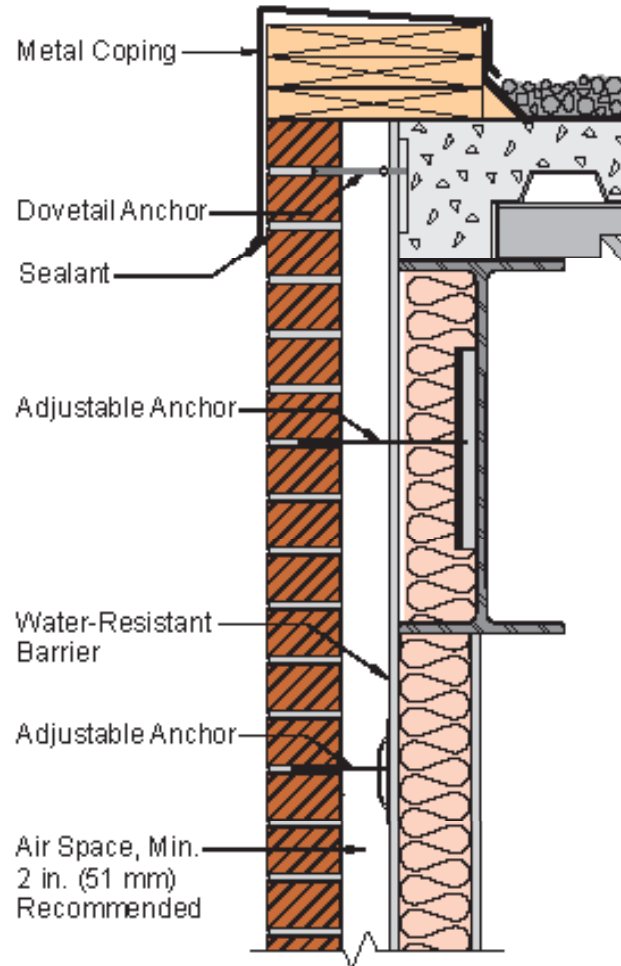

Figure 10
Gravel Stop

barriers are membranes made of polyethylene, polypropylene or polyolefin. They are intended to prevent air leakage through the building envelope, hence reducing the associated energy losses and moisture movement. Most allow the transmission of vapor, while some also act as vapor retarders. Manufacturers provide data based on different standards, including 1) ASTM D 726, Test Methods for Resistance of Nonporous Paper to Passage of Air and 2) ASTM E 283, Test Method for Determining the Rate of Air Leakage Through Exterior Windows, Curtain Walls, and Doors Under Specified Pressure. For this reason, caution should be exercised when evaluating and specifying air barriers.

Vapor retarders minimize moisture movement due to water vapor diffusion and are made of materials similar to air barriers. While some air barriers will also inhibit vapor transfer, all vapor retarders can be air barriers if they are installed and thoroughly sealed with no tears or holes. Some manufacturers cite test data based on ASTM E 96, Test Methods for Water Vapor Transmission of Materials. However, this test does not account for fastener penetrations, electrical outlets, or joints in the retarder. Materials which qualify as vapor retarders should have a perm rating of 1 or less.

Mortar Type

Mortar plays an important role in the flexural strength of a brick veneer wythe. Out-of-plane strength tests of full-scale walls indicate that the bond between mortar and brick units is the most important single factor affecting wall strength when resisting horizontal joint cracking. Mortar should conform to ASTM C 270, Specification for Mortar for Unit Masonry. A designer should select the mortar with the lowest compressive strength that is compatible with the project requirements. The compatibility between a particular brick and mortar should be examined when determining mortar type. Flexural bond strength of a particular brick/mortar combination can be determined using ASTM C 1357, Test Methods for Evaluating Masonry Bond Strength. Type N mortar is suitable for most veneer brickwork, except in areas below grade, where Type S mortar should be used. Type S mortar is recommended

where a higher degree of flexural resistance is required. Admixtures and additives for workability are not recommended since they can potentially weaken the mortar. Admixtures containing chlorides should never be used since they could greatly increase the probability of efflorescence and corrosion. For more information, refer to the *Technical Notes 8 Series*.

Movement Provisions

Brickwork will expand and contract as will all building components. Brick is subject to permanent expansion as a result of freezing and moisture absorption. Mortar will shrink as it cures. Changes in temperature will cause brick to expand and contract. Moisture expansion can continue for years while thermal movement and mortar contraction will occur periodically, contingent upon temperature and moisture content. As a result, brickwork will continually change in size during its life.

To accommodate this movement, brick veneer should be designed in discrete sections which are allowed to move independently of each other. This is accomplished through the use of expansion joints and bond breaks detailed into the veneer. An expansion joint consists of a vertical or horizontal opening through the brick wythe that is closed with a sealant joint and elastic materials. These joints separate each section of brickwork and isolate it from other sections. Expansion joints must be designed and constructed to permit anticipated movements. Further, expansion joints must be located and constructed so as not to impair the integrity of the wall.

The spacing and placement of vertical and horizontal expansion joints must be done on a case-by-case basis. Each wall must be examined to determine its potential for movement based on its length, openings, offsets, corner conditions, wall intersections, means of support, changes in wall heights and parapets. These features influence how the brickwork reacts to movement in a wall. Any portion of wall not able to resist induced stress should be isolated by an expansion joint. For more information, refer to the *Technical Notes 18 Series*.

Vertical Expansion Joints. A vertical expansion joint consists of an opening through the brick wythe closed with a backer rod and sealant. A compressible pad may be used in the joint to ensure no mortar is placed in the expansion joint. Such pads can be made of premolded foam or neoprene as shown in [Figure 11](#). Vertical expansion joints should extend from the foundation to the top of the brickwork without deviating from vertical. When this is not possible, they can be terminated at horizontal expansion joints. Generally, the spacing of vertical expansion joints should not exceed 30 ft (9.14 m) in walls without openings. Vertical expansion joints are also recommended where site walls adjoin buildings and at the corners of large openings. Building corners should have a vertical expansion joint located within 10 ft (3.05 m) of the corner. When a vertical expansion joint is located within 10 ft (3.05 m) of the corner, the vertical expansion joint on the other wall forming that corner should be placed at the typical spacing between expansion joints. For example, if the spacing between vertical expansion joints on a straight wall is 25 ft (7.62 m), then the spacing of expansion joints around a corner could be 10 ft (3.05 m) on one side of the corner and 15 ft (4.57 m) on the other side. Plan offsets and setbacks of a wall should also include a vertical expansion joint on inside corners.

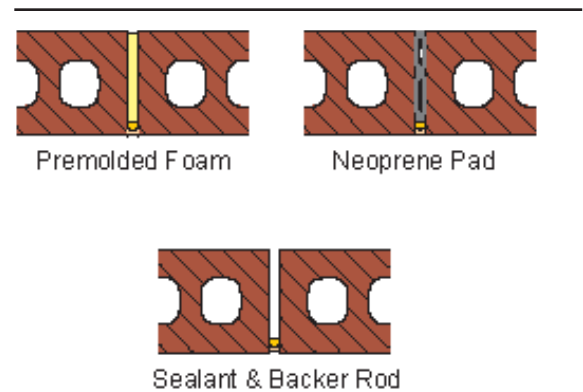

Figure 11
Vertical Expansion Joints

Horizontal Expansion Joints. A horizontal expansion joint cannot function unless there is some means of supporting the brickwork above it. Usually this is accomplished by a shelf angle. Shelf angles should have a horizontal expansion joint below them. These joints are located between the bottom of the shelf angle and the brickwork below. They consist of a sealant joint and either an opening or compressible pad behind them. Refer to [Figure 6](#).

Bond Breaks. When a different material, such as concrete masonry, cast stone or precast concrete, is incorporated into a brick wall, differential movement between the two materials is likely to occur. In such cases, a bond break may be used to separate it from the surrounding brickwork. This break allows for movement between the two materials and diminishes horizontal or vertical cracking. A bond break is achieved by installing a layer of No. 15 asphalt felt or flashing between the other material and the mortar joint surrounding it. For further information on bond breaks, see *Technical Note 18A*.

Horizontal Joint Reinforcement

Although not usually required for brick veneer construction, horizontal joint reinforcement can be incorporated into brick veneer walls to alleviate cracking from high internal stress or to have the brick serve as a reinforced lintel. Horizontal joint reinforcement is necessary for veneer laid in stack bond, in Seismic Design Categories E and F, and possibly in joints adjacent to different materials. It may be either single or double wire joint reinforcement and must have at least $\frac{5}{8}$ in. (15.9 mm) mortar cover. Horizontal joint reinforcement can also be used above and below the corners of masonry openings for added strength.

Brick

Brick are usually selected on the basis of their appearance which includes color, texture and size. To assure quality, brick units should conform to one of the following: 1) ASTM C 216, Specification for Facing Brick 2) ASTM C 652, Specification for Hollow Brick 3) ASTM C 1405, Specification for Glazed Brick or 4) ASTM C 126, Specification for Ceramic Glazed Structural Clay Facing Tile, Facing Brick and Solid Masonry Units. The use of salvaged brick is not recommended since such brick may not bond properly with mortar and may be less durable. For further information on brick specifications and salvaged brick, see the *Technical Notes* 9 Series and 15, respectively.

CONSTRUCTION

Construction requirements are found in model building codes and in referenced specifications. *Specification for Masonry Structures*, ACI 530.1-05/ASCE 6-05/TMS 602-05 [Ref. 11], is invoked by the MSJC Code. [Ref. 2]

Project manuals prepared for specific buildings also contain construction requirements.

All materials at the job site should be stored off the ground and under adequate cover to prevent deterioration and contamination. Cement and lime should be kept dry. Foreign material must be kept out of sand. Brick should not be placed directly on the ground to preclude any potential staining from the earth.

A box or other measuring tool should be used for measuring sand when mortar is mixed at the job site. Only full bags of cement and lime should be added to the mixer unless accurate volumetric measurements are used. Retempering of mortar by adding water is permitted as necessary to maintain consistency. Caution should be exercised when retempering white or colored mortar to avoid color changes. Water content and stiffness of mortar during tooling also affect color. All mortar should be used within 2½ hours of mixing. See *Technical Note 8B* for further information on controls for mixing mortar.

Brick which have an initial rate of absorption (suction) of more than 30 g/min•30 in² (30 g/min•194 cm²) should be wetted and permitted to surface dry prior to laying when using mortar cement or masonry cement. This will increase the bond between the mortar and the brick by slowing the absorption of water from the mortar. For additional information, refer to *Technical Note 7B*.

Hot or cold water protection may be necessary if temperatures are above 90 °F (32.2 °C) or below 40 °F (4.4 °C). When temperatures are above 90 °F (32.2 °C) and wind exceeds 8 mph (12.9 km/hr), mortar should be used within 2 hours of mixing and finished brickwork may need to be fog sprayed with water. For construction with temperatures below 40 °F (4.4 °C), brick units should be at least 20 °F (-6.7 °C) or above when placed with mortar. Mortar must not be frozen and should have a temperature between 40 °F (4.4 °C) and 120 °F (48.9 °C) when placed. Additional wind breaks and enclosures may be necessary within certain lower temperature ranges. The MSJC Specification [Ref. 11] contains requirements for hot and cold water construction. For further information, see *Technical Note 1* in addition to the *Hot and Cold Water Masonry Construction Manual*. [Ref. 5]

Care should be taken to completely fill all bed and head joints with mortar. Conversely, any location not intended to receive mortar, such as air spaces, weeps and expansion joints, should be kept clean and free of mortar and mortar droppings. Mortar joints should be properly tooled to enhance the water resistance of the wall by consolidating the mortar. Joints should be tooled when thumbprint hard with a jointer tool slightly larger than the joint. Concave, "V" or grapevine mortar joints are the most water resistant since they do not provide a ledge for water to remain on the brickwork.

Protection

Protection of unfinished walls is extremely important. The entry of rain or snow into brickwork in progress may increase the potential for efflorescence and distress in the finished wall. Wind screens and enclosures may also be necessary in hot or cold water.

MAINTENANCE

Most brickwork is virtually maintenance free. If properly designed, detailed and constructed, brickwork maintenance should be minimal. However, brick veneer/steel stud wall systems should be inspected periodically to ascertain performance and identify any potential problems. Ideally inspections should be performed on a seasonal basis and on an annual basis as a minimum. Such inspections should address sealant joints, plumbness of the wall, cracking, etc. In this way, repairs and corrections can be initiated prior to the occurrence of severe problems. For additional information regarding maintenance, see the *Technical Note 46*.

SUMMARY

The brick veneer/steel stud wall system is a viable construction option when proper attention is given to design and detailing, material specification, construction and maintenance procedures.

The information and suggestions contained in this Technical Note are based on the available data and the combined experience of engineering staff and members of the Brick Industry Association. The information contained herein must be used in conjunction with good technical judgment and a basic understanding of the properties of brick masonry. Final decisions on the use of the information contained in this Technical Note are not within the purview of the Brick Industry Association and must rest with the project architect, engineer and owner.

REFERENCES

1. Arumala, J.O. and R.H. Brown, *Performance Evaluation of Brick Veneer with Steel Stud Backup*, College of Engineering, Clemson University, Clemson, SC, 1982.
2. *Building Code Requirements for Masonry Structures (ACI 530-05/ASCE 5-05/TMS 402-05)*, The Masonry Society, Boulder, CO, 2005.
3. *Exterior Wall Construction in High-Rise Buildings*, Canada Mortgage and Housing Corporation, Ottawa, ON, 1991.
4. *GalvInfoNote #19, "Selection Coating Thickness (Weight or Mass) for Galvanized Steel Sheet Products"*, Rev 2.2, International Lead Zinc Research Organization, Research Triangle Park, NC, September, 2003.
5. *Hot and Cold Water Masonry Construction*, Masonry Industry Council, Schaumburg, IL, 1999.
6. KPFF Consulting Engineers and Computech Engineering Services, *Report on Behavior and Design of Anchored Brick Veneer/Metal Stud Systems*, Seattle, WA, September, 1989.
7. McGinley, W.M., Warwaruk, J., Longworth, J. and Hatzinikolas, M., *Masonry Veneer Wall Systems, Structural Engineering Report #156*, Department of Civil Engineering, University of Alberta, Edmonton, AB, January, 1988.
8. *North American Specification for the Design of Cold-Formed Steel Structural Members*, American Iron and Steel Institute, Washington, DC, 2001.
9. Rutila, D. A., "Innovations in Brick Veneer", *The Construction Specifier*, Vol. 51, No. 11, October, 1998.
10. "Self Drilling Fasteners-The Basics", *The Construction Specifier*, Vol. 42, No. 9, August 1989.
11. *Specification for Masonry Structures (ACI 530.1-05/ASCE 6-05/TMS 602-05)*, The Masonry Society, Boulder, CO, 2005.
12. Tuluca, A., "Thermal Bridges in Buildings", *The Construction Specifier*, Vol. 49, No. 11, October, 1996.