



# TECHNICAL NOTES on Brick Construction

1850 Centennial Park Drive, Suite 301, Reston VA 20191 | [www.gobrick.com](http://www.gobrick.com) | 703-620-0010

## Technical Notes 36 - Brick Masonry Details, Sills, and Soffits Rev [July/Aug. 1981] (Reissued Jan. 1988)

**Abstract:** Detailing of brick masonry is both an art and a science. Recommendations are provided for the development of successful details using brick masonry and other materials. Detailing of sills and soffits is specifically addressed. Performance, esthetic value and economics are the principal considerations in the development of successful details.

**Key Words:** brick, connections, construction, design, detailing, economics, esthetic value, function, performance, prefabrication, sills, soffits, structural stability.

### INTRODUCTION

Successful detailing of brick masonry is both an art and a science. Proper details should result in a structure which is pleasing to the eye, but more importantly, performs well over its lifetime. Good detailing is not accidental, it requires proper planning. This planning may involve close cooperation between the architectural, engineering and construction disciplines in the early stages of the design process.

There are three items which should be considered in the development of a successful detail. These are: 1. Performance considerations; 2. Esthetic value considerations; and 3. Economic considerations. The last two of these items may be traded off against each other. But, the first is mandatory and if it is not the primary concern, the detail may, and probably will, be doomed to failure. This failure can manifest itself in several ways: cracking, structural failure, moisture penetration to the interior, or efflorescence, to mention a few.

It is possible to have a successful detail while compromising either the esthetic value or the economic considerations. But, it is impossible to have a successful detail if the performance considerations are compromised. A successful detail can be developed with excellent esthetic value while completely ignoring the economic considerations or vice versa, but to ignore the performance considerations is to invite trouble.

### APPROACH TO DETAILING

#### General

Proper planning in the development of brick details is essential to the successful execution of that detail in the field. The designer must be familiar not only with the properties of the various materials involved, but also how they go together in the construction process and how they will perform, both individually and together in service. The most esthetically pleasing detail is of no benefit if it can't be built, or does not perform its intended function.

The designer should always keep in mind that different materials react to temperature and moisture changes in different ways. While in some cases these differences may be minor, in others they may be significant. If they are not properly addressed, the result can be facade failures, such as leaking, bowing, cracking, etc. For a discussion of differential movement, see *Technical Notes 18 Series*.

#### Performance Considerations

Performance is all-important if the detail is to be successful. There are three items which must be considered in the development of a detail which will provide satisfactory performance. They are: 1. Functional considerations; 2. Structural stability; and 3. Construction considerations. In the development of the detail, it is imperative that all of these items be given proper consideration.

**Functional Considerations.** One of the first steps in the development of a successful detail is to determine the function of the element. The designer must determine the purpose of the element, and how the element will affect the overall performance of the building. Typical questions which should be addressed are: 1. Is the element to serve as a weather-tight enclosure? 2. Will stresses, axial, flexural or shear, be developed in the member? 3. Should it channel and direct the flow of moisture? 4. Is it to seal the top of a vertical element? 5. Is its purpose merely for esthetic value? Only after the designer has determined the required functions of the element can he begin to consider the other factors which will dictate the final design.

**Structural Stability.** The designer must develop a detail which ensures that all applied loads can be adequately resisted by the element or that they are transferred to other elements of the structure which can resist them. These applied loads may be axial, transverse, shear or in the case of prefabricated elements, loads due to transportation and erection. One area of concern is the manner and adequacy of the connection of the element to the structure. It is imperative that these connections be structurally sound, to ensure structural stability of the element.

**Construction Considerations.** The designer should take great care to ensure that the details can be easily executed in the field. This requires that the designer be knowledgeable in current construction practices. While some innovation may be necessary and beneficial, the detail should not require radical deviation from conventional construction practices. Typically, the more simple and straightforward the detail is, the easier it is to construct and thus, the better its performance. In some instances, the construction can be simplified by prefabrication of the element. Care should be taken by the designer to ensure, to the greatest extent possible, that the detail does not require several crafts to be working in the same location at the same time.

### **Esthetic Value Considerations**

The designer must also determine how best to fulfill the functional requirements and yet provide the desired esthetic value. This involves decisions on materials, colors and textures, and other esthetic considerations. The configuration of the element is also an important esthetic consideration. The designer may decide to project or recess parts of the element to provide shadow lines or to use a different bond pattern to call attention to the detail. The esthetic value of the detail is limited only by its function, its ease of construction, the designer's imagination and possibly its economic feasibility.

### **Economic Considerations**

A detail, to be successful, should have the capability of being constructed economically. Economics involves both materials and labor. A successful detail requires that both the quantity and quality of materials be closely controlled. The use of excess materials to achieve the function of the detail should be avoided.

Details which require very specialized skills by the crafts involved should be avoided. If very specialized skills are required, there is usually a reduction in productivity of the craftsmen and an increase in cost.

## **SILLS**

### **General**

The prime function of a sill is to channel water away from the building. The sill may consist of a single unit or multiple units; it may be built in place or prefabricated; and it may be constructed of various materials.

### **Esthetic Value**

The desired esthetic effect may be achieved through the use of special shaped units, either manufactured or cut to the desired shape. A word of caution concerning manufactured special shapes-while most manufacturers are capable of making special shapes to match the color and texture of the units selected for the project, there will be an added cost for each special-shaped unit. The added cost for the special shapes is dependent upon the complexity of the configuration of the shape and the number of units of each special shape required. Some manufacturers carry certain special shapes in stock. It may be advantageous to slightly alter the detail so that these stock special shapes may be used in lieu of one with a slightly different configuration.

The appearance of the sill and the overall esthetic appeal of the structure may also be achieved by the use of a contrasting color or texture or by use of materials other than brick for the sill. Esthetics may also be affected by the use of a different bond pattern than that used in the adjacent wall. See Figs. 1 and 2.



**General Studies/Classroom/Instructional Resources Center -  
State University Agricultural and Technical College - Delhi, New York**

**FIG. 1**

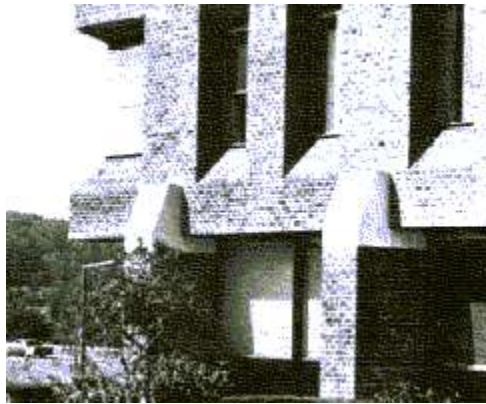

**Westgate Corporation Building - McLean, Virginia**

**FIG. 2**

## **Materials**

Sills for use in brick masonry construction are typically brick, concrete, stone or metal. The selection of material is primarily dependent upon the required esthetic effect. But it is also important to note that metal, concrete and stone sills normally require fewer joints than do brick sills, and therefore provide fewer potential avenues for water penetration. Once the decision of which material to use is made, then decisions concerning the quality of that material can be made. Whichever material is selected, it should be of high quality. A discussion of brick and mortar properties is found in *Technical Notes 7B Revised*.

Flashings for use in sills can be of a number of materials, such as copper, lead or plastics, see *Technical Notes 7A Revised* for additional information. Aluminum and asphaltic-impregnated felt are *not* recommended for use as flashing materials. Aluminum is not recommended since alkalis in the cement of the mortar may attack it and cause corrosion. Asphaltic-impregnated felt is not recommended because it is easily punctured during construction. For the same reason, plastic films of less than 20 mil thickness should also be avoided. Once the flashing has been punctured, it ceases to fulfill its function, thus in place flashing should be inspected for

punctures and tears, and appropriately repaired prior to laying brick masonry on the flashing. Also, some plastics are subject to continued degradation after having been exposed to sunlight for an extended period of time.

## Details

**General.** Since the primary function of sills is to divert water away from the building, the top surface should slope downward and away from the building. In the case of brick sills, see Figures 3 and 4, the slope should be at least 15 deg from horizontal. This may vary somewhat according to the sill configuration of the window unit, particularly in the case of wood windows. The sill should extend a minimum of 1 in. (25 mm) beyond the face of the wall at its closest point to the wall, see Fig. 3. In some instances, it may be necessary that the brick units at the ends of the sills be uncured units so that no cores are exposed to view.

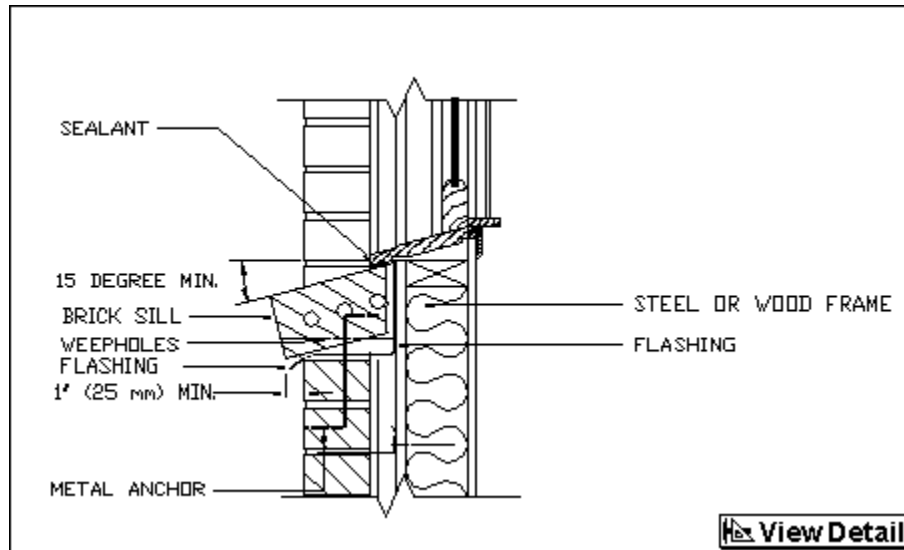

**Sill in Frame/Brick Veneer Construction**

**FIG. 3**

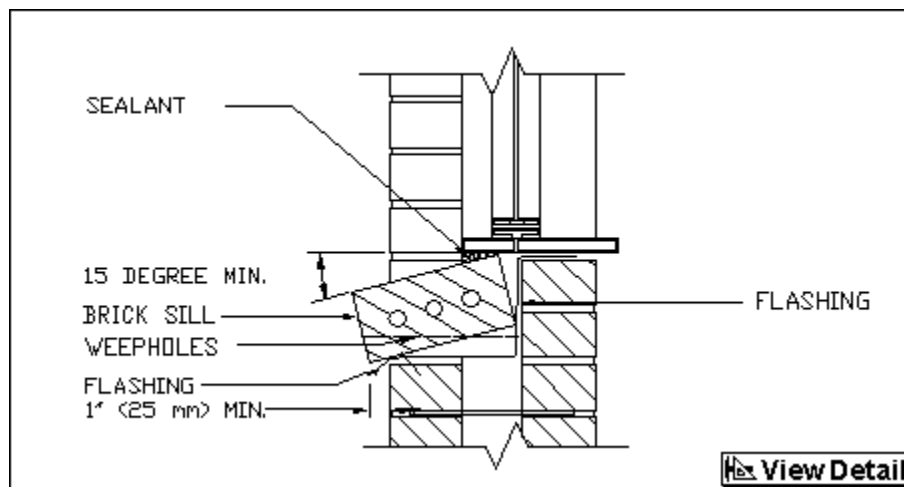

**Sill in Cavity Wall Construction**

**FIG. 4**

When concrete or stone sills are used, they should be sloped away from the building, and also sloped from the ends toward the center, see Figs. 5 and 6. The slope away from the building should be at least 15 deg from horizontal, the slope from the ends should be 1/8 in. (3 mm) to 12 in. (300 mm) toward the center of the sill. For sills longer than 4 ft ( 1.2 m), the slope should extend for at least a distance of 2 ft (600 mm) from the ends, see Fig. 6.

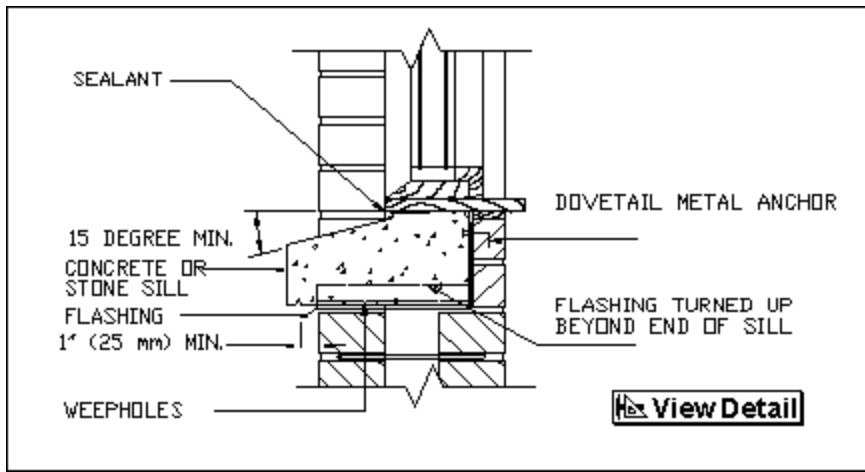

Concrete or Stone Sill

FIG. 5

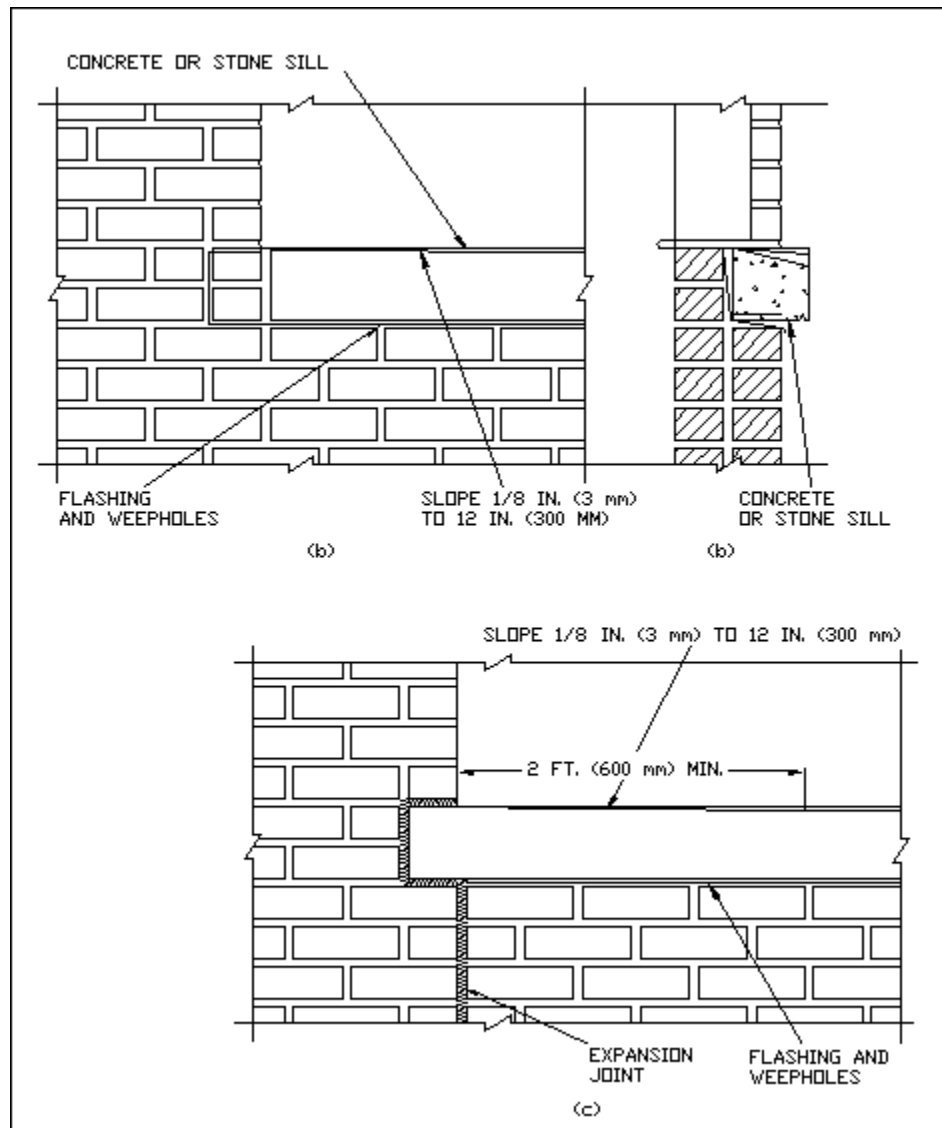

Concrete or Stone Sill

FIG. 6

**Flashing and Weepholes.** In general, when a collar joint, cavity or air space is interrupted, such as at sills, at the base of the walls, at lintels over openings and at shelf angle supports, flashing should be provided in the wall. The function of flashing is to serve as a collector for any moisture penetrating the wall or the sill. It is important that the flashing extend through the brick to the exterior face of the wall at the lower end of the flashing and be turned down at least to in. (6 mm) to form a drip. The flashing at the sill should extend beyond the ends of the sill to the first head joint outside of the jamb of the opening, and should be turned up and outward for a distance of at least 1 in. (25 mm) at each end, see Fig. 5. If the ends are not turned up and out, the moisture collected on the flashing will have a path into the adjacent wall and there is no way to predict where it may go. The purpose of turning the flashing up and out is to assure that the moisture stays on the flashing until it drains from the wall. See *Technical Notes 7A Revised* for a discussion of materials to be used as flashing.

Once moisture penetrating the wall or sill has been collected on the flashing, it must be removed from the wall. This is the function of weepholes. Weepholes may be installed in several ways, see *Technical Notes 21C*. Weepholes should be placed on top of the flashing, *not* one course up. If wick-type materials are employed, or if hidden flashing is used, the weepholes should have a maximum horizontal spacing of 16 in. (400 mm). If open weepholes with no wicks are used, the horizontal spacing may be increased to 24 in. (600 mm) maximum.

**Drips.** Every sill should be provided with a drip. The function of the drip is to prevent water from returning to the exterior face of the wall. The drip of a properly sloped brick sill is the lower corner of the brickwork. A drip in a concrete or stone sill is usually formed, or cut into the bottom face of the sill, as shown in Figs. 5 and 6. The drip on a concrete or stone sill can be cut in several shapes, Vee-shape, rectangular, semi-circular, or a combination of these. The shape of the drip is not important, but its presence and location are important. The inner lip of the drip should be located a minimum of 1 in. (25 mm) from the exterior face of the wall, , as shown in Fig. 5.

**Connections.** In brick masonry sills of short length, 4 ft. (1.2 m) or less, no special anchorage is necessary. However, sills of brick, concrete, metal and stone having long runs should be anchored to the masonry below or behind the sill, see Figs. 3 and 5. This will require penetration of the flashing below or behind the sill. Care must be taken to ensure that these penetrations are adequately sealed so that the flashing functions as intended.

Attachment of the sill to the window will vary with window type and manufacturer. It is most important that the joint where the sill and window make contact be sealed with a high-quality sealant, see *Technical Notes 28 Revised* and *28B Revised*.

**Expansion Joints.** When expansion joints are necessary, it may be desirable to install them in vertical alignment with window jamb lines. If this is done, the expansion joint should also be installed through the sill. This will enable the expansion joint to perform as intended.

If the sill extends beyond the jamb of the opening and an expansion joint is required at the jamb, then the expansion joint should be continuous around the entire sill extension, as should the flashing, see Fig. 6.

## **Construction**

In the past, sills for use in brick masonry construction have generally been built in place, using conventional construction practices. A trend during recent years has been to use prefabricated sills, particularly when combined with a spandrel and soffit, see *Technical Notes 40 Series*. This type of construction will be further discussed in the Soffits portion of this *Technical Notes*.

When prefabricated brick, pre-cast concrete, or stone sills are used, they should have section lengths as long as is practical. The lengths will be determined by ease of handling and erection and the sills' ability to resist erection stresses. The length of sill sections should be limited to a length that can easily be handled by equipment already on the jobsite. The joints between long sill sections should be constructed using a soft joint. It may also be necessary, in very long runs of sill, to provide expansion joints at the ends where the sill abuts the jamb.

## **SOFFITS**

### **General**

Detailing of soffits for brick masonry requires special considerations. The primary function of a brick masonry soffit is to enclose the building while providing an esthetically pleasing appearance. There are two primary

considerations in addition to esthetic value in the detailing of soffits: the structural stability of the system and whether it can be easily and economically constructed using conventional methods.

Though prefabrication has not been widely used for total projects, it has been successfully used in many specialized applications and is considered a conventional construction method. Prefabrication has been widely used in the construction of soffits and may provide the most economical approach on certain projects. Construction of soffits in place often requires expensive forming and shoring. However, if there is only a small area of soffits involved on a given project, this may be the most efficient method.

## Materials

Soffits generally are reinforced and grouted in some manner, whether built in place or prefabricated. Several projects have been constructed using reinforced and grouted hollow units, conforming to ASTM C 652. See *Technical Notes 17* for information on reinforcement and grout. Properties for brick and mortar are discussed in *Technical Notes 7B Revised*.

There are several high bond mortar additives available which may allow the designer to eliminate the reinforcement and grout. However, it should be noted that the high bond mortars do not work well with all brick units. The instructions of the additive manufacturer must be strictly followed, and a pre-design testing program should be carried out, see *Technical Notes 39A*.

## Design

There are several questions which must be answered when designing soffits. Some deal with esthetic value, some with structural stability and some with construction. The primary esthetic concern is configuration. Should the soffit be horizontal, or sloped, should it be integral with the spandrel or separate? The primary design concern is structural. How should it be detailed to assure structural soundness, under all loading conditions, including any loads imparted during erection? This may require detailing and construction practices unfamiliar to the designer and contractor since this is not like a wall and demands careful consideration. One of the earliest decisions to be made about the construction of the soffit is whether it will be best to construct it in place, or to prefabricate it. The configuration, structural and economic considerations may dictate the method of construction to be used. See Figs. 7 and 8.



**BIA Headquarters Building - McLean, Virginia**

**FIG. 7**



Evans Library, Texas A&M University - College Station, Texas

FIG. 8

### Details

**General.** Each soffit entails its own unique detailing problems. These may include: configuration, support available from the surrounding structure, space restriction on built in place soffits and construction sequencing. The manner in which these problems are solved will determine how successfully the soffit will perform.

**Flashing and Weepholes.** Normally, soffits do not require flashing or weepholes. However, in some applications, both may be required, see Fig. 9. In other applications, only weepholes may be required, since the inclusion of flashing in some cases may impair the structural stability of the soffit. It can only be stressed that the detailer should always keep in mind the primary function of flashing and weepholes in determining whether they are needed in any particular application. Their primary functions are:

Flashing - collect and divert to the weepholes any moisture which might penetrate the element.

Weepholes - convey all collected and diverted water to the exterior.

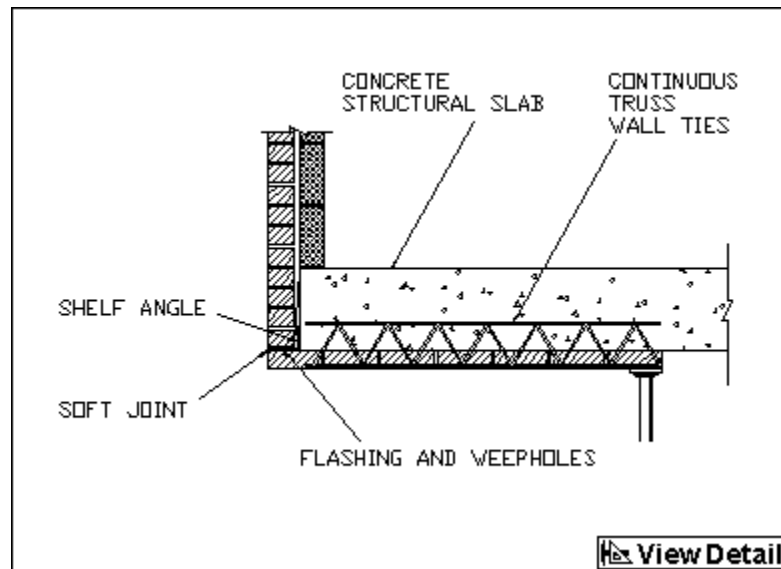

Built-in-Place Brick Soffit

FIG. 9

**Connections.** Whether the soffit is prefabricated or built in place, its connection to the structure is the most demanding detail for the designer to develop. Previously developed details may be totally inappropriate in the present situation. Connection details are critical in providing structural stability to the soffit. In detailing



connections, it is important to keep one principal always in mind. That principle is: *Keep It Simple*. The simplest connection details are in most cases the most successful.

**Expansion Joints.** The installation of expansion joints, in most cases, should be avoided in soffits; however, it may be necessary to provide expansion joints when soffits are to be installed over large areas. The installation of expansion joints may cause problems in providing structural stability of the element and require additional connections to the structure. If it is necessary that expansion joints be installed in soffits, it is important to remember that the function is *expansion* control. This is provided by resilient joints which can be compressed to provide for the movement of brick masonry, especially during hot weather, due to thermal expansion of the brick masonry and return to its original shape when the temperature is cooler. Reinforced and grouted brick masonry does not usually require expansion joints.

## Construction

Structural and economic considerations normally determine the construction methods to be used. While the detailer does not normally specify the manner in which the detail is to be executed during construction, the method of support and economic aspects determined by the detail will affect the method of construction chosen.

The method of supporting the soffit, both its permanent support and support during construction, has a direct bearing on the method of construction selected. The economics of constructing the element can be affected by configuration, structural support and materials selection. Economics in turn may well be the final determining factor in the selection of the construction methods employed.

When a soffit is constructed in place, it sometimes requires a complicated system of centering and falsework which must be left in place for a number of days. Normal practice is to provide spacer strips on the forms which locate each unit within the form and provide a joint on the exposed face suitable for tuckpointing once the form is removed, see Fig. 10. These strips should be the width of the joint and a minimum of 1/2 in. (13 mm) in height. After the units have been placed on the form, the upper side is grouted and ties are placed in the joints for anchorage to the structure. After several days of curing, the forms are stripped and the joints can then be tuckpointed. The number of days required for curing is dependent upon conditions at the site during the curing period and the materials used. See *Technical Notes 7* for tuckpointing recommendations.

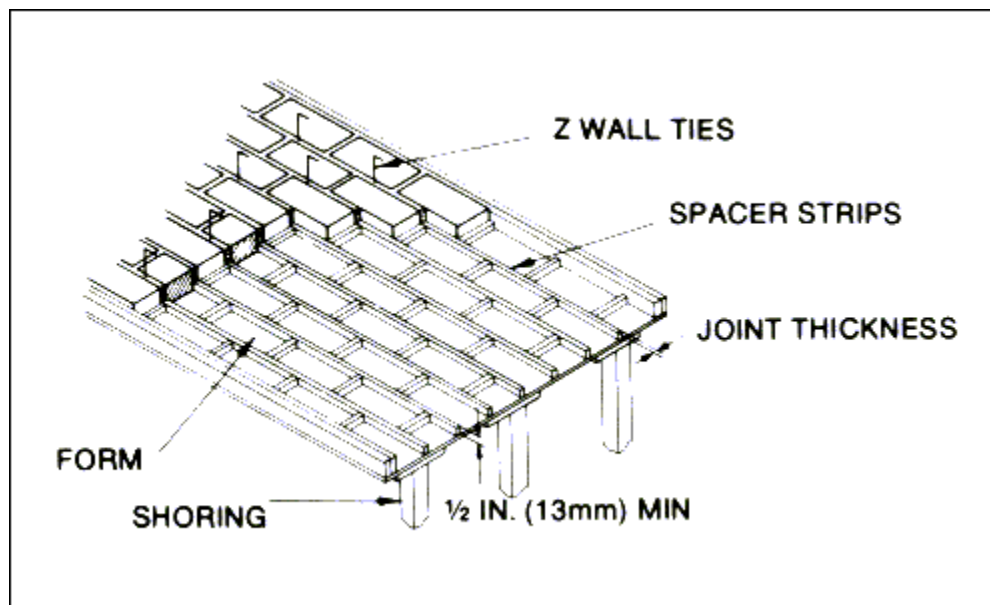

**Built-in-Place Brick Soffit Forming**

**FIG. 10**

In some cases, the use of built in place soffits may be precluded. Then, prefabrication may be the most logical and economical approach, see *Technical Notes 40 Series*. This method of construction has been used very satisfactorily on many projects. On most of the projects where it has been used, the soffit is built integral with a spandrel cover and a sloped sill, see Figs 11 and 12.

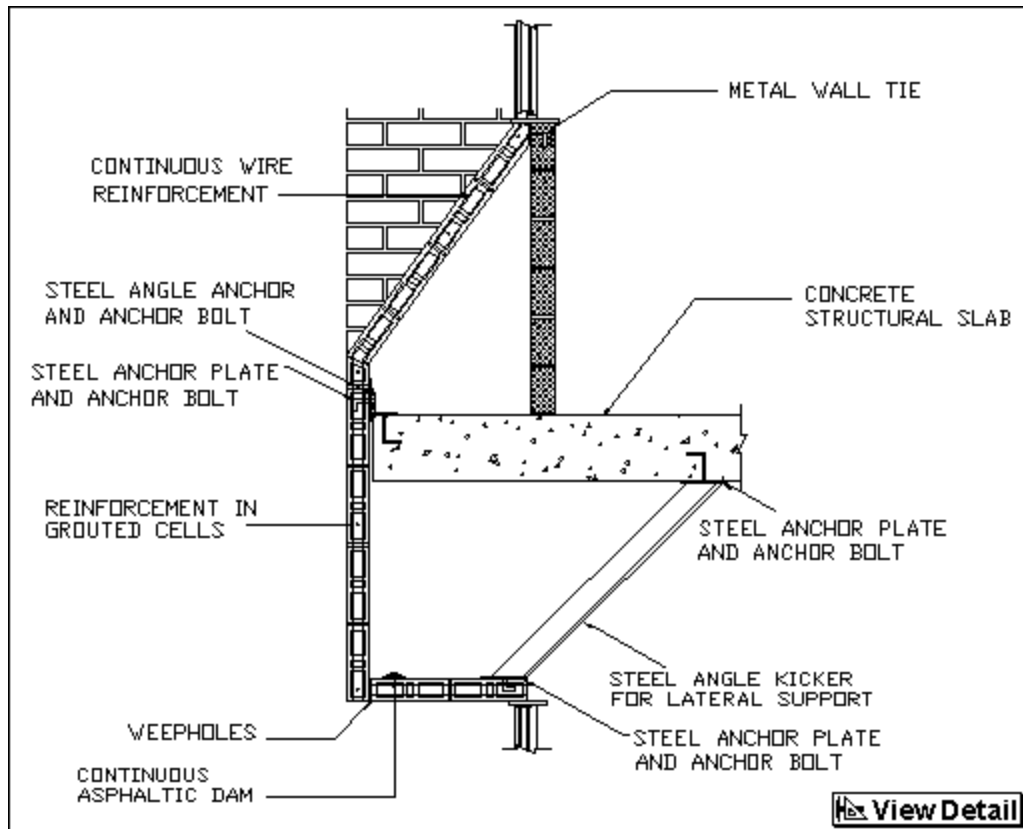

Prefabricated Brick Sill, Spandrel and Soffit

FIG. 11

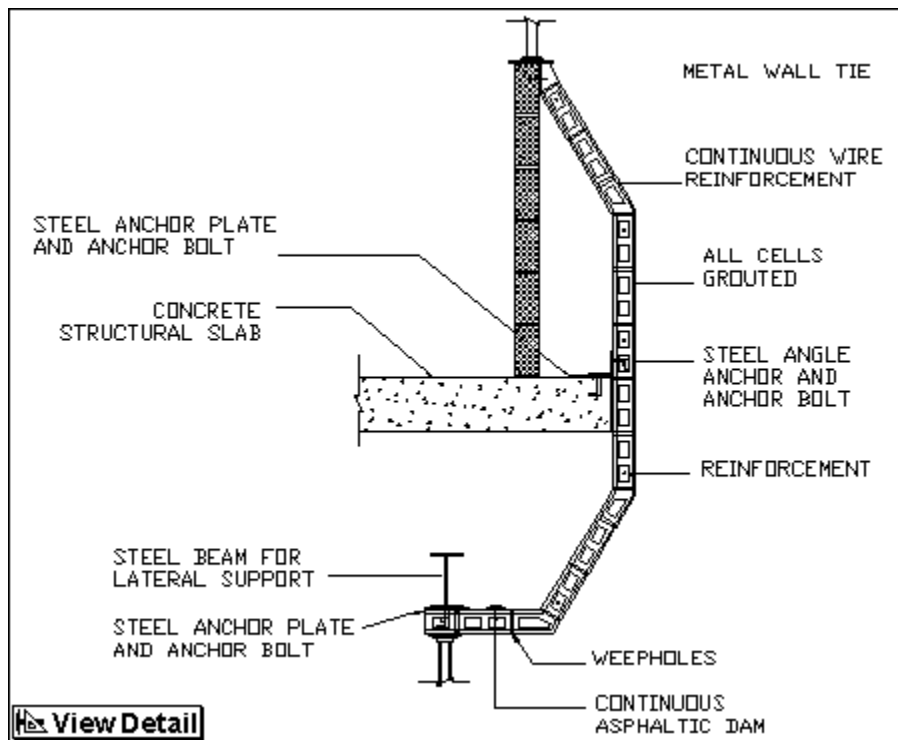

Prefabricated Brick Sill, Spandrel and Soffit

FIG. 12

## SUMMARY

The designer, when developing details for sills and soffits, should keep in mind the function of the element being detailed, the esthetic value he wishes to achieve, the structural stability of the element, and the economics of construction. It is essential to provide details which allow the elements to perform their primary functions as well as possible. In order to do this, the designer must select the proper materials, locate them in the proper place, and provide sufficient information so that the element can be properly constructed. Several decisions and assumptions must be made by the designer because each project and each element on the project must be satisfactorily addressed.

This *Technical Notes* addresses the major considerations necessary to successfully detail sills and soffits of brick masonry. In some cases, other considerations may be necessary due to unusual or unique conditions. It is beyond the scope of this *Technical Notes* to address all conditions and combinations of conditions which may occur, therefore the designer or owner, or both, must make the final decision on the details, the materials selected and the construction procedures used. The recommendations made in this *Technical Notes* are merely that-recommendations. The final configuration of the detail must in the long run be based on the designer's application of some or all of the principles set forth here.