



TECHNICAL NOTES on Brick Construction

1850 Centennial Park Drive, Suite 301, Reston VA 20191 | www.gobrick.com | 703-620-0010

Technical Notes 44A - Fasteners for Brick Masonry May 1986 (Reissued Aug. 1997)

Abstract: Fasteners are used extensively in brick masonry construction to attach fixtures, equipment and other objects. This *Technical Notes* discusses the different types of fasteners used in brick masonry construction, their applications, appropriate fastener selection based on brick type, fixture weight, environmental exposure and aesthetics.

Key Words: adhesives, bolts, brick, fasteners, fixtures, hardware, masonry, screws.

INTRODUCTION

This *Technical Notes* is the second in a series that addresses brick masonry anchor bolts, fasteners and ties. The term "fastener", as used in this text, refers to devices for securing equipment, fixtures or other objects to brick masonry. This *Technical Notes* discusses the different fastener types used to attach these items to brick masonry.

When other materials, fixtures, etc., are to be attached to brick masonry, the procedure is relatively simple and can be executed either during or after construction. The designer or builder has a wide variety of fastening methods from which to choose. The final selection will depend largely upon what is to be attached, when it will be attached and the type of brick used in the construction.

TYPES OF FASTENERS

Fasteners can be divided into two general categories: those installed during the construction of the masonry, and those that are installed after the completion of the masonry work.

Fasteners Installed During Construction

Nailing Blocks and Wall Plugs. Wooden nailing blocks and metal wall plugs are placed in mortar joints as the brick are laid (see Figure 1). Wooden nailing blocks are not used today as frequently as they were in the past, but do provide an acceptable means of attachment to brick masonry walls. If wooden blocks are used, they should be of seasoned soft wood to prevent shrinkage and treated to inhibit deterioration. Wooden blocks should be placed only in head joints.

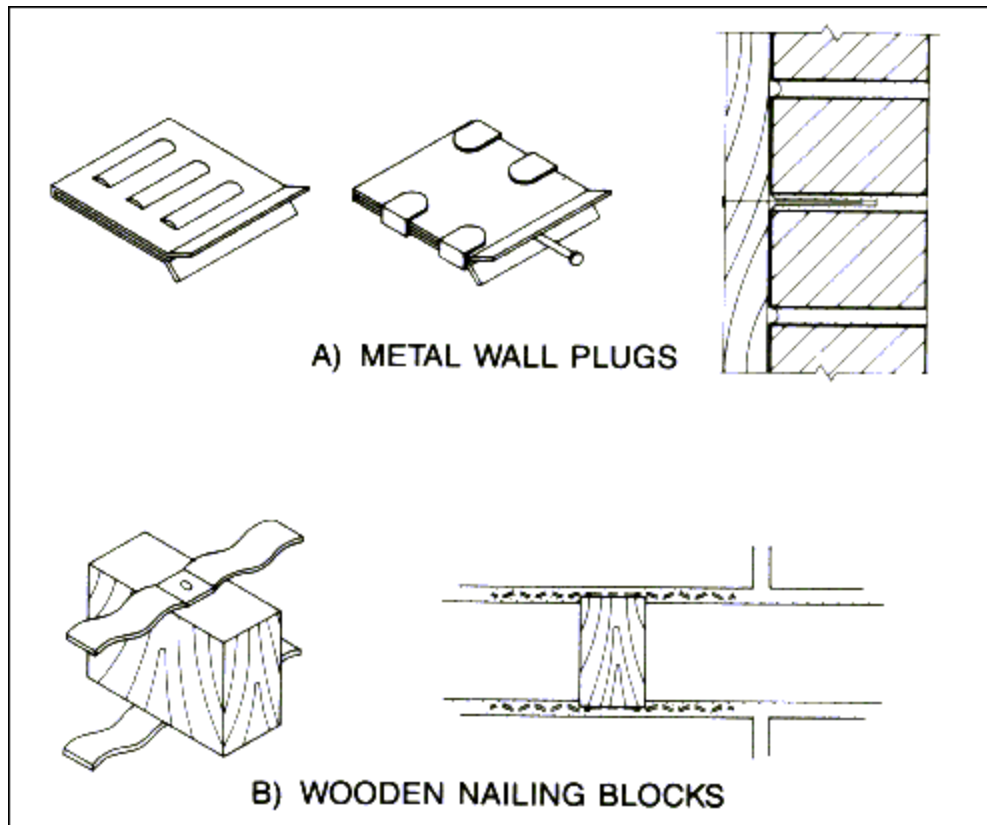

Fasteners Installed During Construction

FIG. 1

Metal wall plugs are made of galvanized metal, and may contain wooden or fiber inserts. Metal plugs are preferred over wooden blocks since problems with shrinkage and decay are not associated with metal plugs. Metal plugs may be placed in either head joints or bed joints of masonry.

The primary consideration when using fasteners installed during construction is location. Their exact location is not a serious problem when used to attach moldings, such as baseboards, chair rails, etc., but it may be difficult to predetermine fastener locations for fixtures, cabinets, shelving, etc. For this reason, post-construction fasteners have virtually replaced wooden blocks and metal nailing plugs for fastening to masonry.

Post-Construction Fasteners

Screw Shields and Plugs. Screw shields and plugs are produced in plastic, fiber, rubber, nylon and lead (see Fig. 2). Some are advertised by their manufacturers as vibration-resistant, chemical-resistant or water-resistant. These fasteners are generally used for lightweight attachments and are typically installed in mortar joints or may be placed directly into solid masonry units (see Fig. 3).

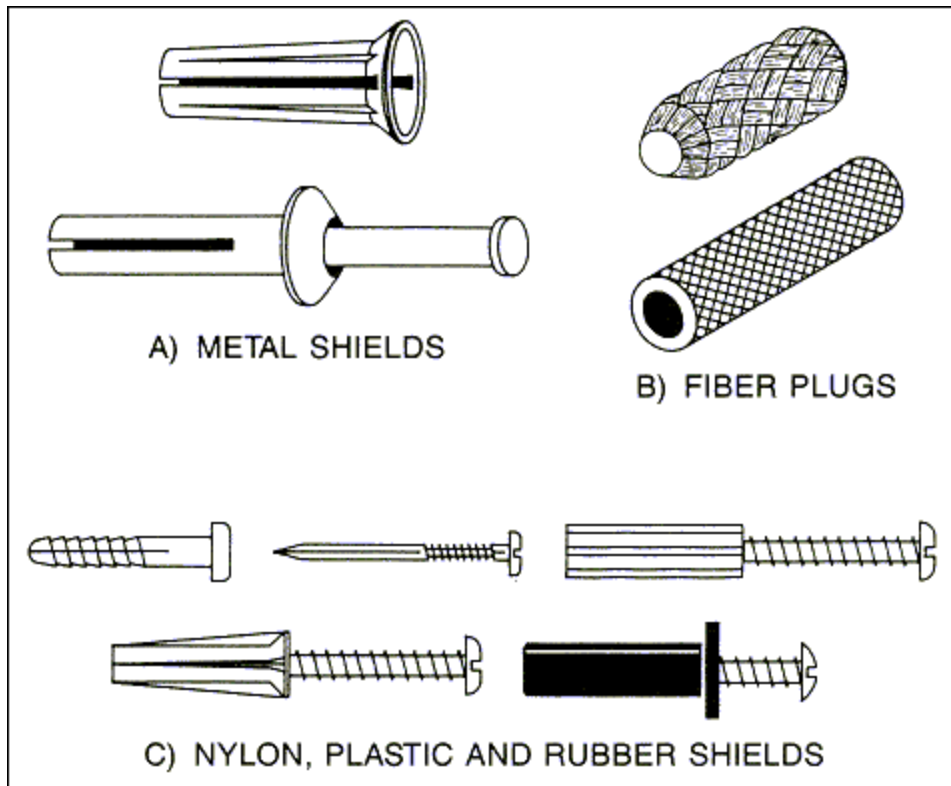

Shields and Plugs

FIG. 2

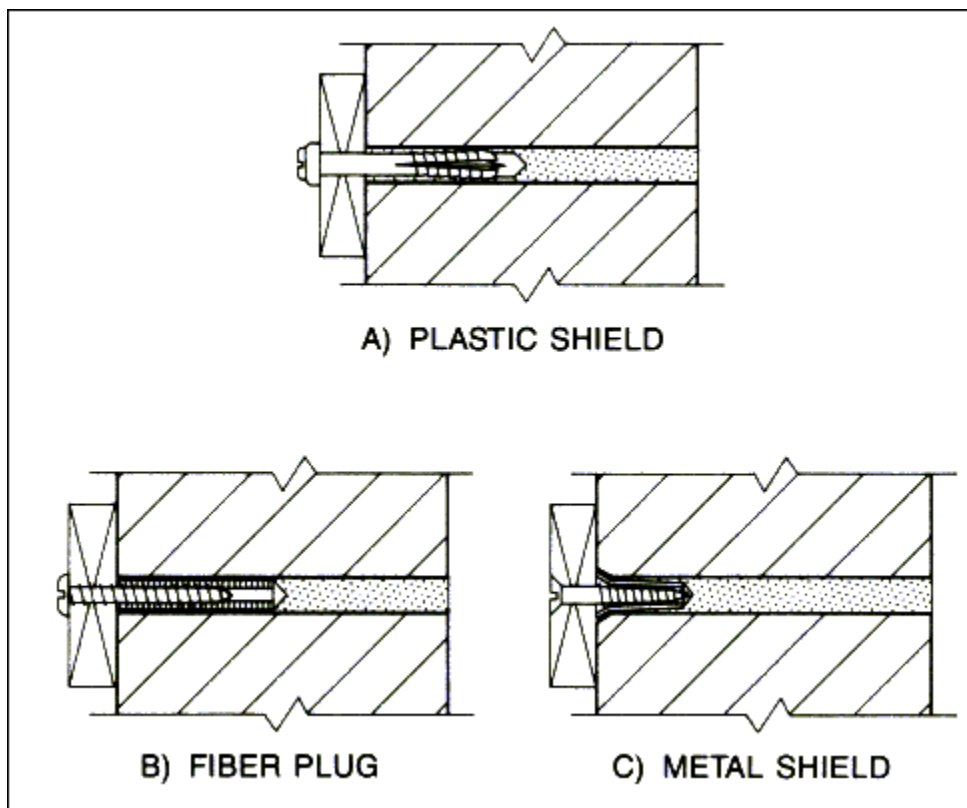

Shields and Plugs Installed

FIG. 3

Bolts and Screws. Several types of bolts and screws are available for use in both solid and hollow masonry. These fasteners are generally used to attach medium to heavy-weight fixtures. Toggle bolts (made of steel or plastic), hollow wall screws, small diameter sleeve anchors and screws are used to attach fixtures to walls constructed of hollow units (see Fig. 4). These fasteners may be placed in holes drilled through bed joints or through the unit faces into hollow cells (see Fig. 5). Small diameter sleeve anchors, wedge anchors, screws and lag bolt shields (see Fig. 6) are used to attach fixtures to solid masonry and are usually installed in mortar joints (see Fig. 7).

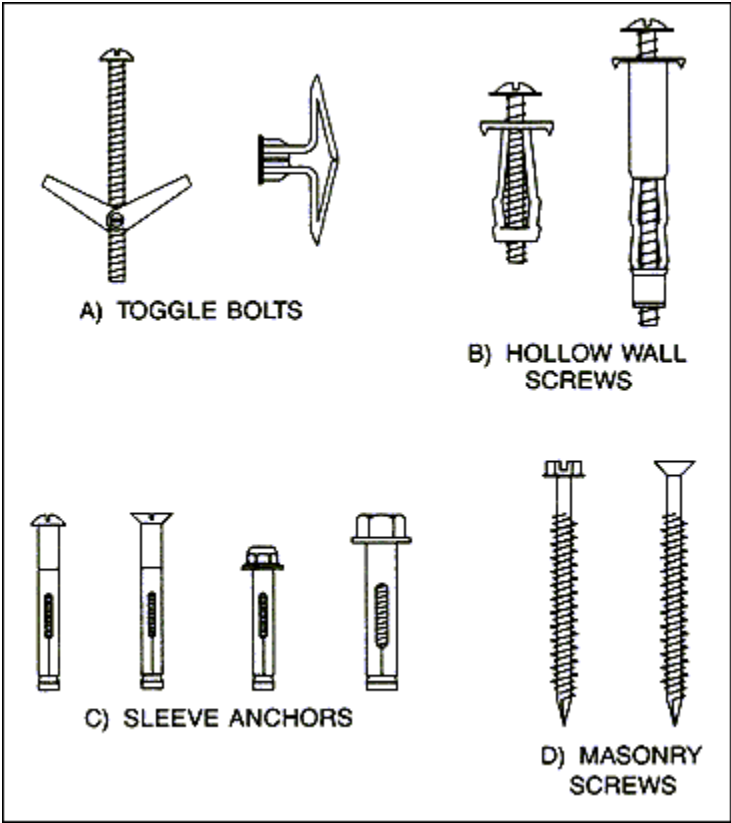

Fasteners for Hollow Masonry Units

FIG. 4

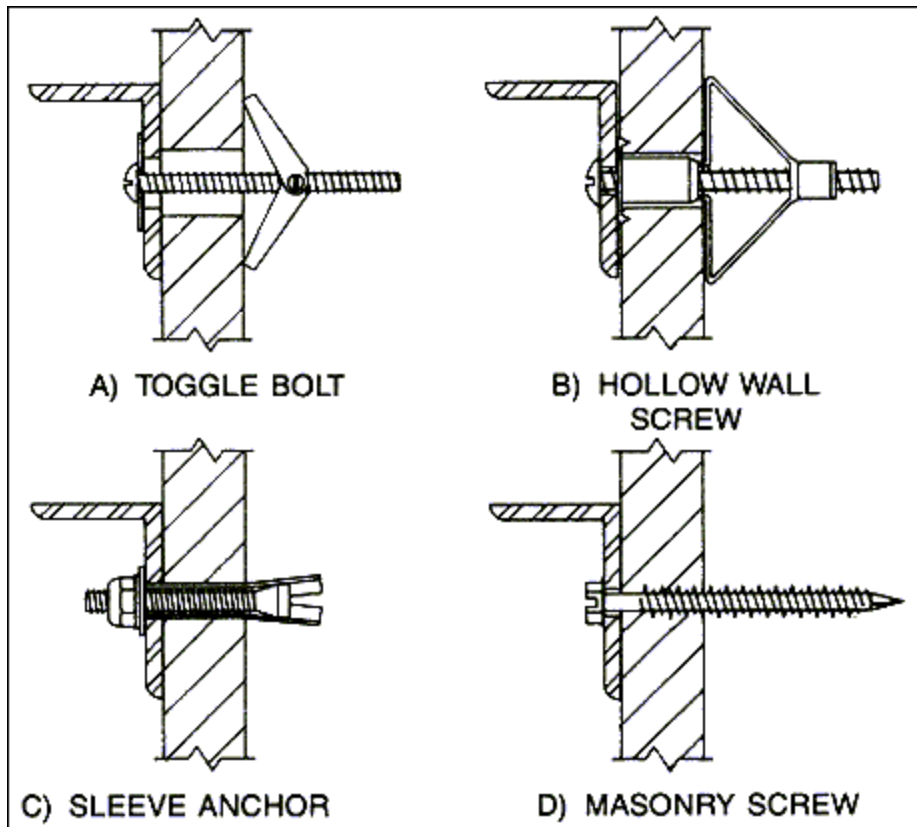

Fasteners Installed in Hollow Units

FIG. 5

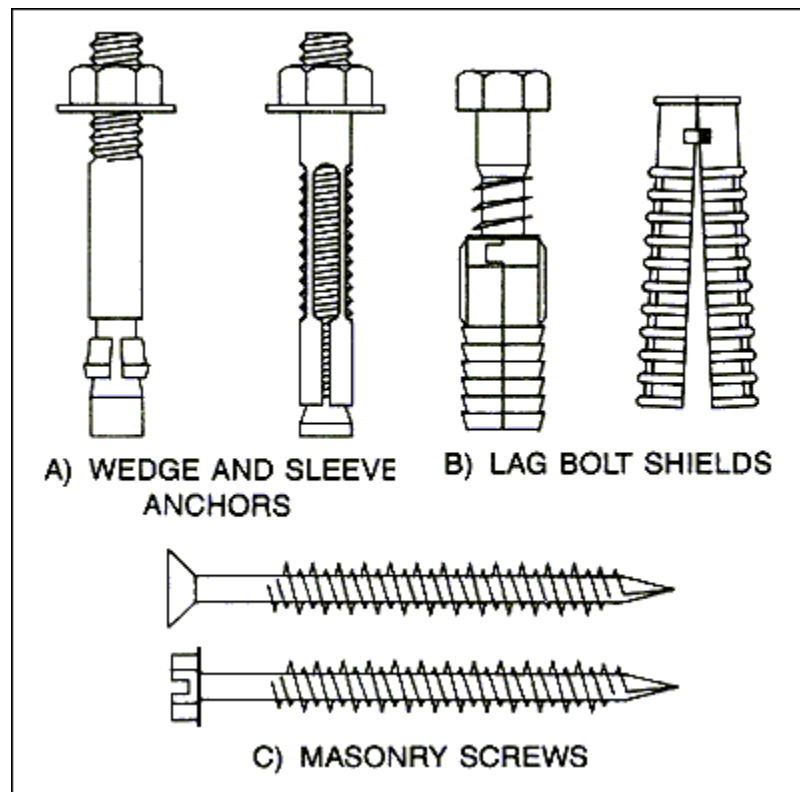

Fasteners for Solid Masonry Units

FIG. 6

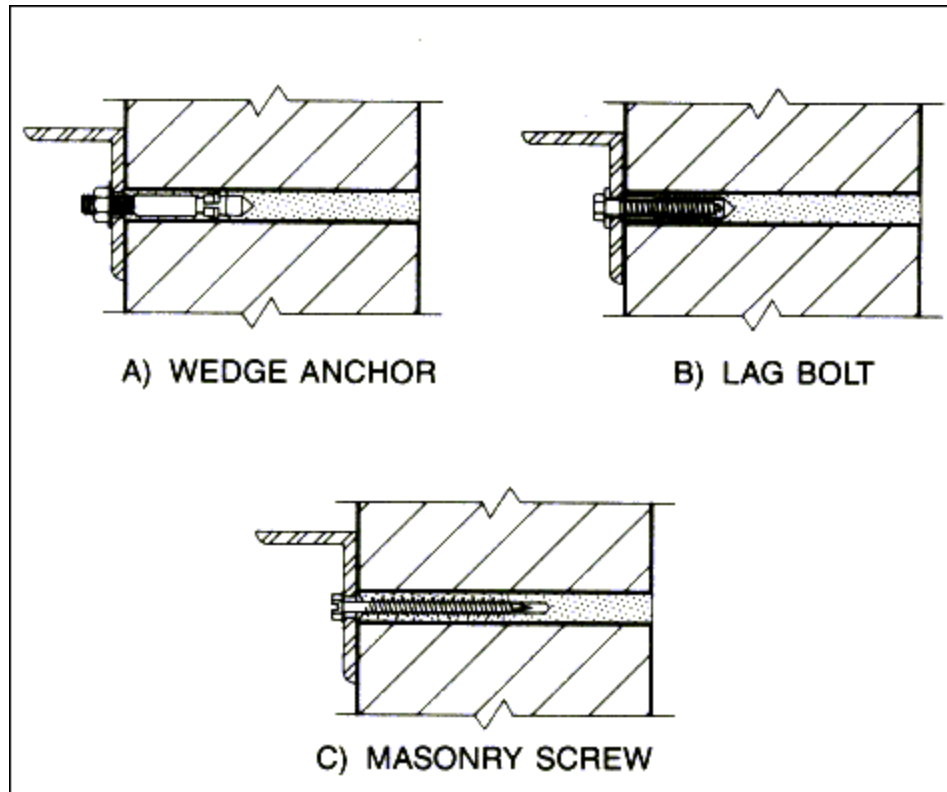

Fasteners Installed in Solid Masonry Units

FIG. 7

Nails. Case-hardened cut and spiral nails (masonry nails) are often used to attach furring strips to masonry walls (see Fig. 8). If used, the nails should be hammered directly into the mortar joints and not into the brick units. Caution should be exercised when nails are used in single-wythe walls with exposed exterior faces. The nails could open small cracks in the mortar joints, allowing water to penetrate the wall (see *Technical Notes 7F* for problems associated with water penetration).

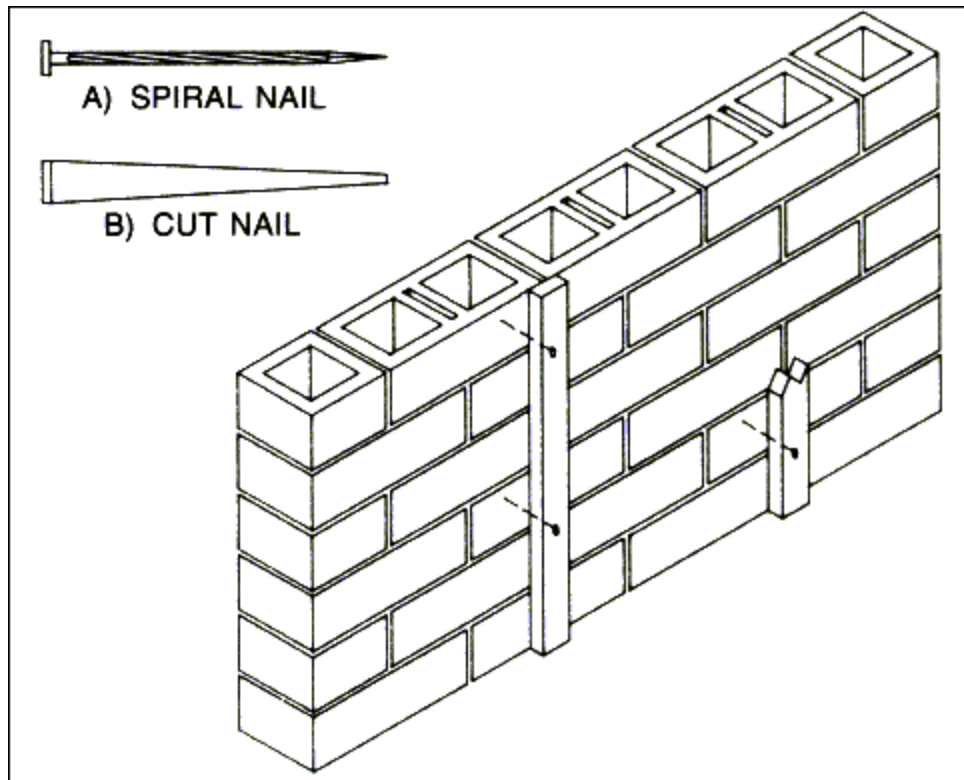

Masonry Nails

FIG. 8

Powder-Driven Fasteners. Powder-driven fasteners are hardened steel pins that are driven into masonry by means of a powder-actuated tool (Fig. 9). The power for the tool is provided by a powder charge typically ranging from .22 to .38 caliber with varying charges, depending on the material and required pin penetration. Powder-driven fasteners are generally used on commercial or industrial projects where large volumes of fasteners are required. Several pin styles and lengths are produced for different fastening requirements (see Fig. 10).

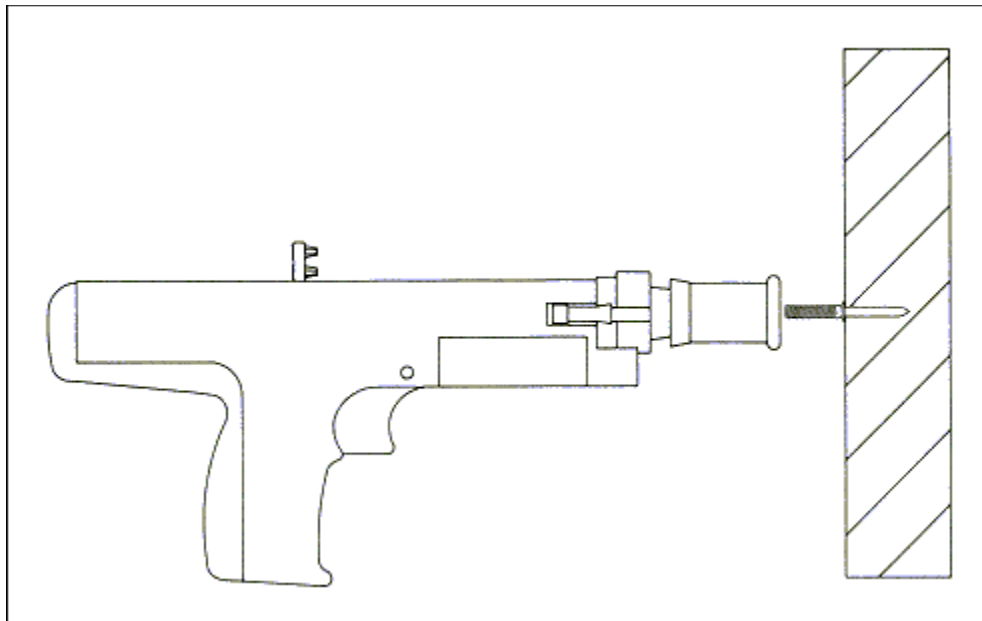

Powder-Driven Fastening Tool

FIG.9

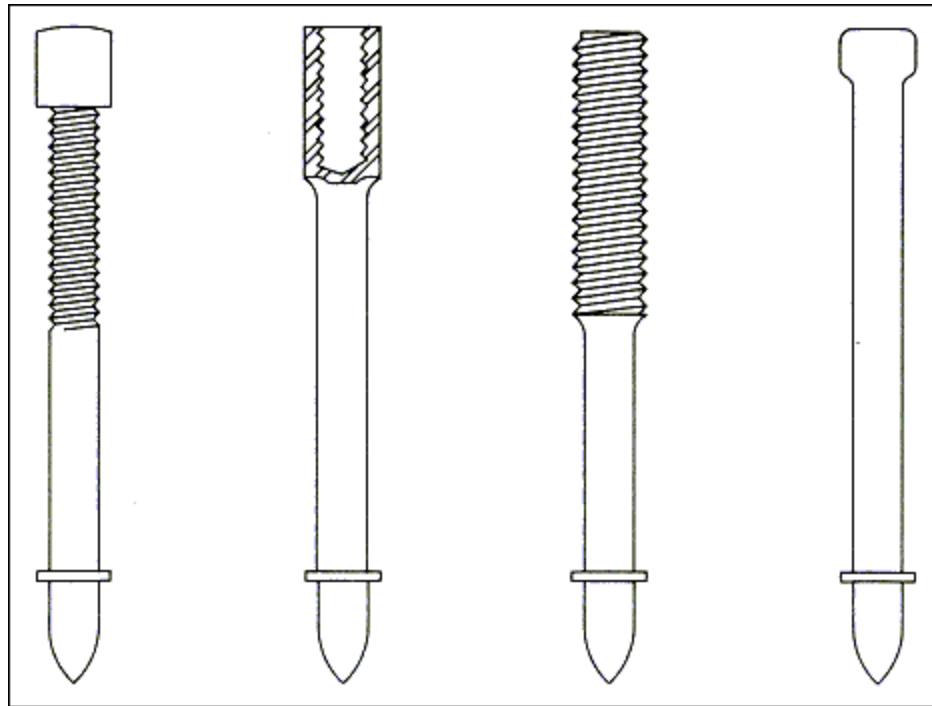

Powder-Driven Pins

FIG. 10

Powder-driven fasteners require special installation equipment, safety equipment and inspection procedures. For this reason, the manufacturer should be contacted to determine proper equipment and installation specifications.

Adhesives. A multitude of adhesives, such as epoxies, mastics and contact cements, is produced for various bonding applications. Many of these produce high bond strengths, have short setting times and offer versatility in bonding different materials. Adhesives may be used to attach furring, electrical boxes, wall paneling, etc. (see Fig. 11). The manufacturer's literature should be referred to when determining the suitability of an adhesive for a particular application. Some adhesives may not bond properly to masonry, may not have the elasticity required to accommodate movements of dissimilar materials and may be affected by exposure to weather, chemicals or temperature extremes.

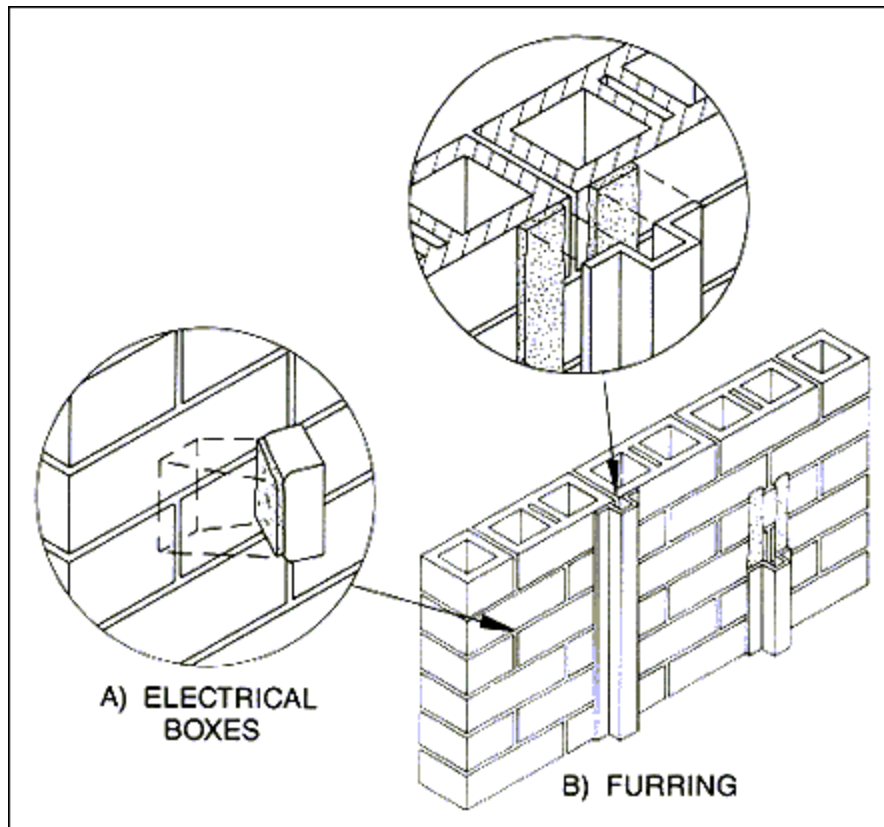

Adhesive Fastening

FIG. 11

FASTENER SELECTION

The selection of an appropriate fastener can usually be based on four considerations: 1) the type of brick used in the construction, 2) the weight of the attachment, 3) the environmental exposure (i.e., interior or exterior) and 4) aesthetics.

Construction and Attachment

The type of brick used in construction will determine the choice of a fastener as either a solid or hollow wall type fastener; the weight of the fixture will determine the size of the fastener required. The fastener selection chart shown in Table 1 can be used as a general guide in selecting a fastener type based on the brick type, installation location and fixture weight.

TABLE 1
Fastener Selection Chart

Fastener	Brick Type			Installation Location			Fixture Weight		
	Solid brick (cored)	Solid Brick (Uncored)	Hollow Brick	Head Joint	Bed Joint	Unit Face	Light	Medium	Heavy
Wooden Blocks	X	X	X	X			X	X	
Metal Wall Plugs	X	X	X	X	X		X	X	
Screw Shields and Plugs	X	X	X	X	X		X		
Toggle Bolts			X		X	X	X	X	X
Hollow Wall Screws			X		X	X	X	X	
Screws	X	X	X	X	X	X	X	X	
Sleeve Anchors	X	X	X	X	X	X	X	X	X
Wedge Anchors	X	X		X	X		X	X	X
Lag Shields	X	X		X	X		X	X	X
Masonry Nails	X	X	X	X	X		X	X	
Powder-Driven Fasteners	X	X		X	X		X	X	
Adhesives	X	X	X	Surface Applied			X		

Environment

Environmental factors may have a definite impact on the long-term service life of fasteners and should be considered in their selection. Environmental factors do not, in general, influence the type of fastener selected, but should influence the choice of fastener based on the material from which the fastener is made. Corrosion is a major concern, especially when fasteners are exposed to the elements or when fasteners are used in areas where contact with corrosive agents is likely.

Steel fasteners used for applications under normal exposure conditions should be galvanized (zinc-coated) to resist corrosion. Lead, copper-coated or brass fasteners also provide adequate corrosion resistance for normal exposures. In applications where fasteners are subject to severe exposure conditions or exposed to chemicals, stainless steel fasteners should be used.

Aesthetics

In most applications, the fastener or fasteners installed will be hidden by the attachment (i.e., cabinets, baseboards, electrical boxes or furring), and the physical appearance of the fastener (usually the head of a screw or bolt) will not be of importance. However, when fasteners are used to attach privacy partitions, lighting fixtures or rails, the head of the fastener is usually visible and required to match or accent the finish of the fixture. In these cases, finished screws or bolts (i.e., chrome or brass-plated, solid brass or painted) can be purchased to match the fixtures. The manufacturers should be contacted to determine the availability and range of finishes available in their products.

SUMMARY

This *Technical Notes* is the second in a series on brick masonry anchors, fasteners and ties. It addresses the types of fasteners available for use in brick masonry construction. Other *Technical Notes* in this series address brick masonry anchor bolts and wall ties.

The products described in this *Technical Notes* may involve the use of hazardous materials, operations and/or equipment. This *Technical Notes* does not purport to address all of the safety practices associated with the use of these products. It is the responsibility of the user of this *Technical Notes* to establish appropriate safety and health practices and determine the applicability of regulatory limitations prior to the use of the products described.

The information and suggestions contained in this *Technical Notes* are based on available data and experience of the technical staff of the Brick Industry Association. This information should be recognized as recommendations and should be used with judgment. Final decisions on the use of the information discussed herein are not within the purview of the Brick Industry Association, and must rest with the project owner, designer or both.

REFERENCES

1. *Technical Notes on Brick Construction 7F*, "Moisture Resistance of Brick Masonry - Maintenance", Brick Industry Association, Reston, Virginia, February 1986.
2. *Construction Sealants and Adhesives*, 2nd Edition, J. R. Panek and J. P. Cook, John Wiley and Sons, New York, 1984.
3. *Architectural Graphic Standards*. 7th Edition, C. G. Ramsey and H. R. Sleeper, John Wiley and Sons, New York, 1981.